



Medium delivery centrifugal pumps for agricultural applications. Equipped with an open impeller that allows the pumping of nonclean liquids, guaranteeing the free passage of small solids (Ø max. 10 mm).

Construction features

Pump body	cast iron
Motor bracket	cast iron
Impeller	Noryl® or brass
Mechanical seal	ceramic-graphite-NBR
Motor shaft	stainless steel AISI 416
Liquid temperature	Noryl® impeller: 0 - 50 °C brass impeller: 0 - 90 °C
Operating pressure	max 6 bar

Motor

	3~ 230/400V - 50Hz
2 Poles induction motor	1~ 230V - 50Hz (with thermal protection)
Insulation class	F
Protection degree	IPX4

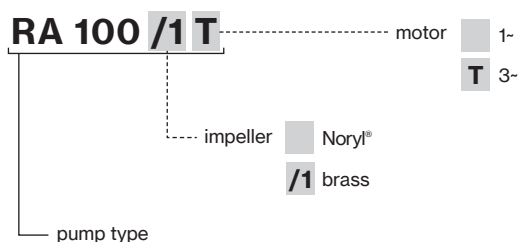

TYPE	LOTS			
	TRUCK		CONTAINER	
	PALLET (cm)	N° pumps	PALLET (cm)	N° pumps
RA	85×110×145	65	85×110×195	91



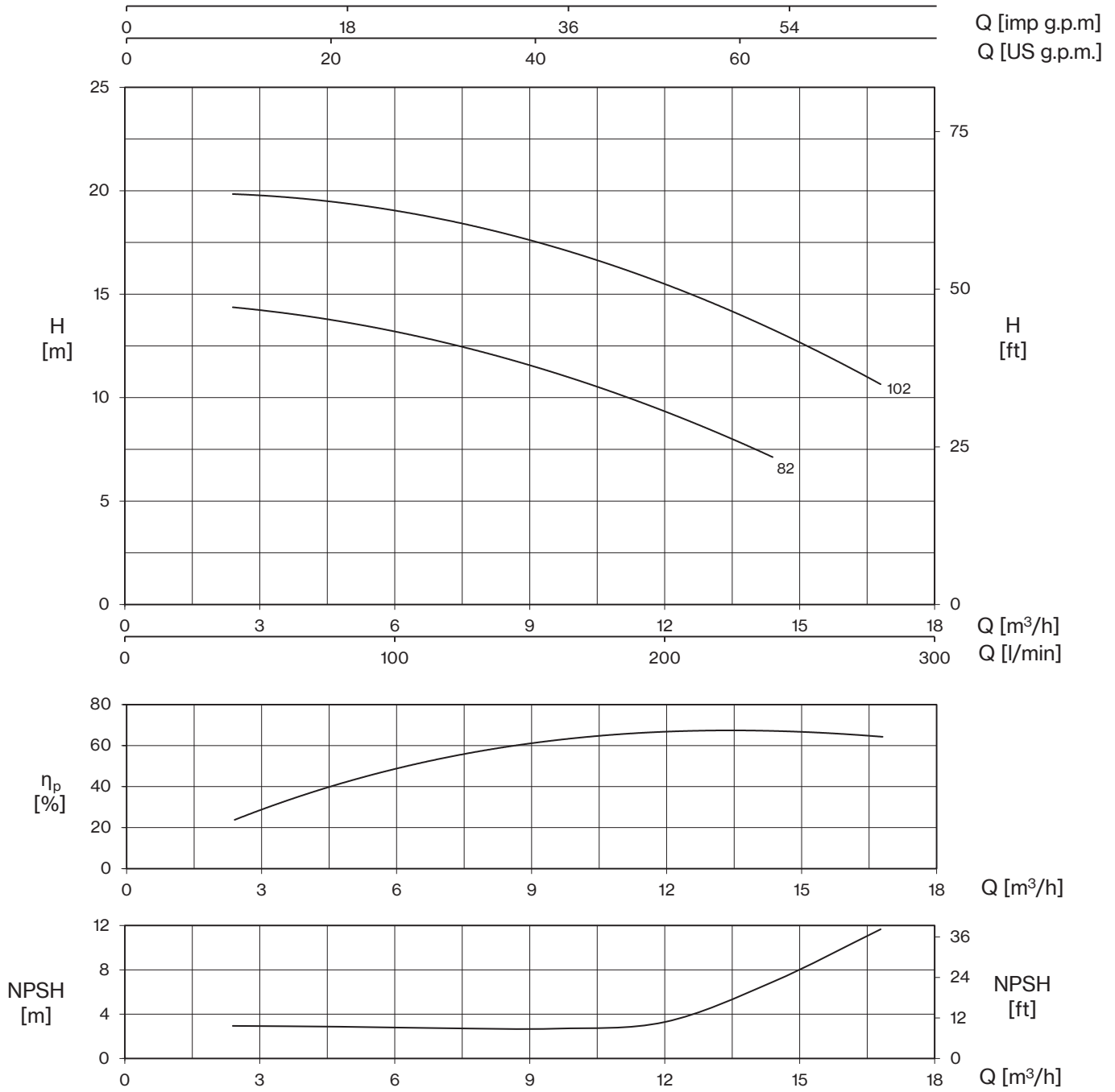

RA

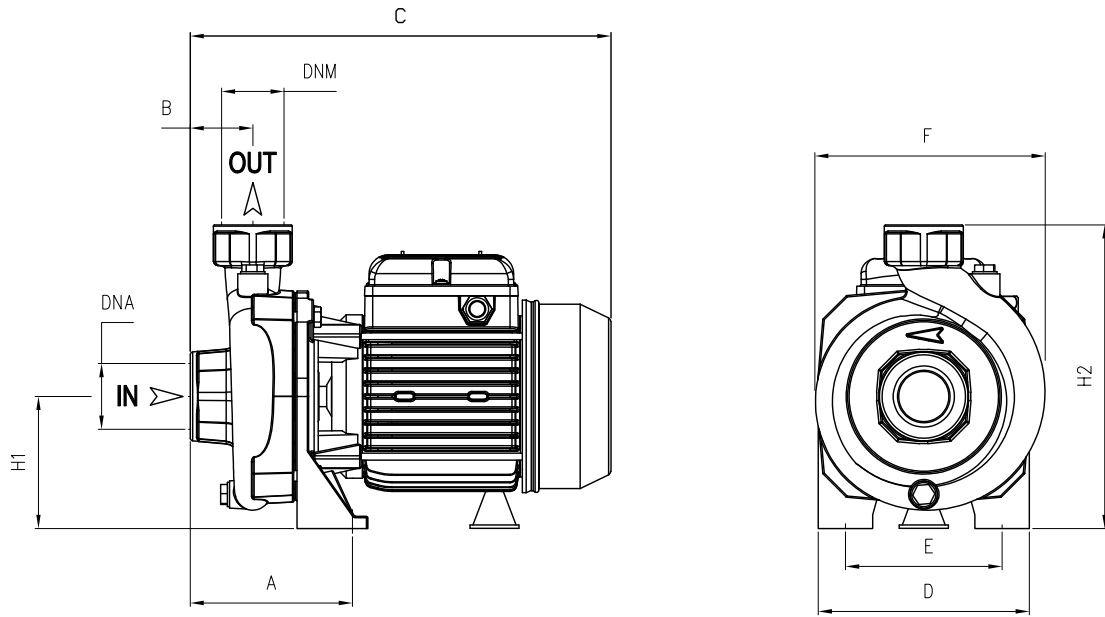

TYPE - 50 Hz		P2		P1		CURRENT		Q (m³/h - l/min)						
1~	3~			1~	3~	1~ 230V	3~ 400V	0	3	6	9	12	14,4	16,8
		HP	kW	kW		A		H (m)						
RA 82	RA 82T	0,8	0,59	0,73	0,83	3,4	1,5	15,0	14,3	13,0	11,6	9,5	7,0	
RA 102	RA 102T	1	0,74	1,14	1,20	5,3	2,4	20,5	19,8	18,9	17,7	15,5	13,5	10,5



TYPE		DIMENSIONS (mm)														
1~	3~	A	B	C	D	E	F	H1	H2	DNA	DNM	I	L	M		
RA 82	RA 82T	120	45	308	155	115	170	97	222							13
RA 102	RA 102T	120	45	308	155	115	170	97	222	1" 1/2 G	1" 1/2 G	325	200	265	14	