



Single-impeller centrifugal pumps, extremely quiet, suitable for domestic, civil and industrial applications. The pumps guarantee constant pressure at the variation of flow rates.

Construction features

Pump body	cast iron
Motor bracket	cast iron (45, 50, 164÷550); aluminum (86-106)
Impeller	Noryl® (45) Noryl® or brass (50÷314) brass (400-550)
Mechanical seal	ceramic-graphite-NBR
Motor shaft	steel AISI 416 (45÷106) steel AISI 303 (164÷550)
Liquid temperature	Noryl® impeller: 0 - 50 °C brass impeller: 0 - 90 °C
Operating pressure	max 6 bar (45÷106) max 8 bar (164÷550)

Motor

	3~ 230/400V - 50Hz
2 Poles induction motor	1~ 230V - 50Hz (with thermal protection up to MEC 80)
Insulation class	F
Protection degree	IPX4

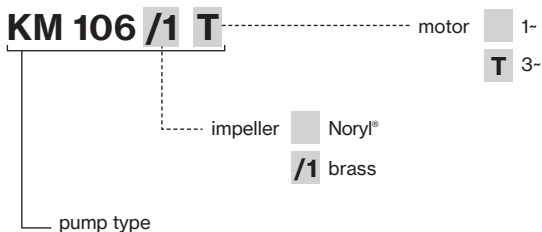

TYPE	LOTS			
	TRUCK		CONTAINER	
	PALLET (cm)	N° pumps	PALLET (cm)	N° pumps
KM 45-50	80×120×145	102	80×120×190	136
KM 86-106	85×110×145	65	85×110×195	91
KM 164÷314	85×110×140	40	85×110×170	60
KM 314 (1~)	85×110×150	24	85×110×180	30
KM 400÷550	85×110×150	24	85×110×180	30

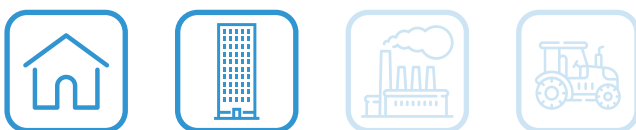

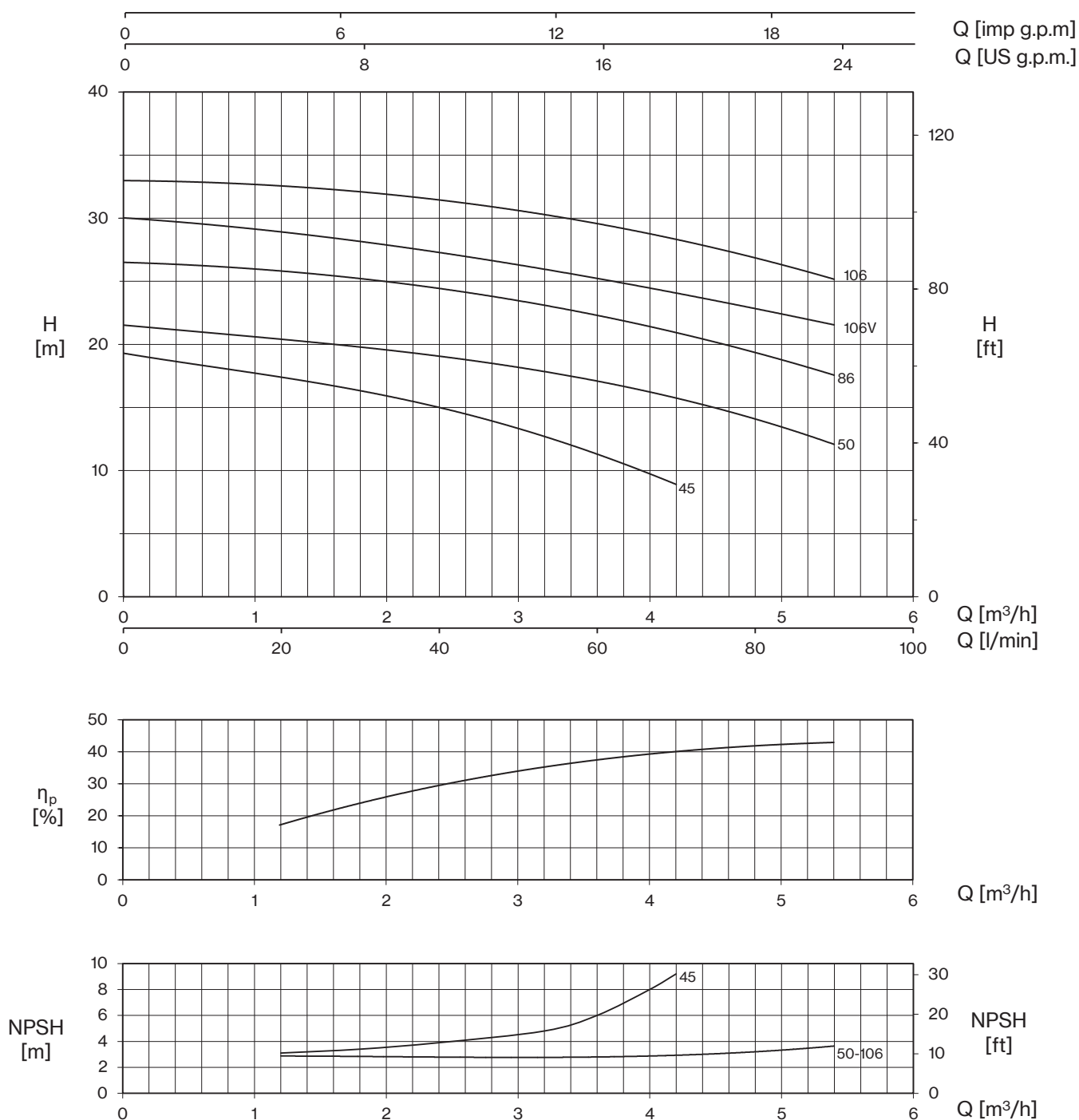

TYPE - 50 Hz		P2		P1		CURRENT		Q (m³/h - l/min)						
1~	3~			1~	3~	1~ 230V	3~ 400V	0	1,2	2,4	3,6	4,2	4,8	5,4
		HP	kW	kW		A		0	20	40	60	70	80	90
		H (m)												
KM 45	KM 45T	0,4	0,3	0,51	0,56	2,3	1	19,3	17,4	150	11,3	8,9		
KM 50	KM 50T	0,5	0,37	0,59	0,65	2,8	1,1	21,5	20,5	19,0	17,0	15,8	14,2	12,0
KM 86	KM 86T	0,8	0,59	0,9	0,94	4,5	1,7	26,5	25,8	24,5	22,2	20,9	19,5	17,5
KM 106V	-	1	0,74	1,05	-	4,6	-	30,0	29,0	27,2	25,2	24,1	22,9	21,5
KM 106	KM 106T	1	0,74	1,16	1,17	5,7	2	33,0	32,5	31,5	29,6	28,3	26,8	25,2

KM

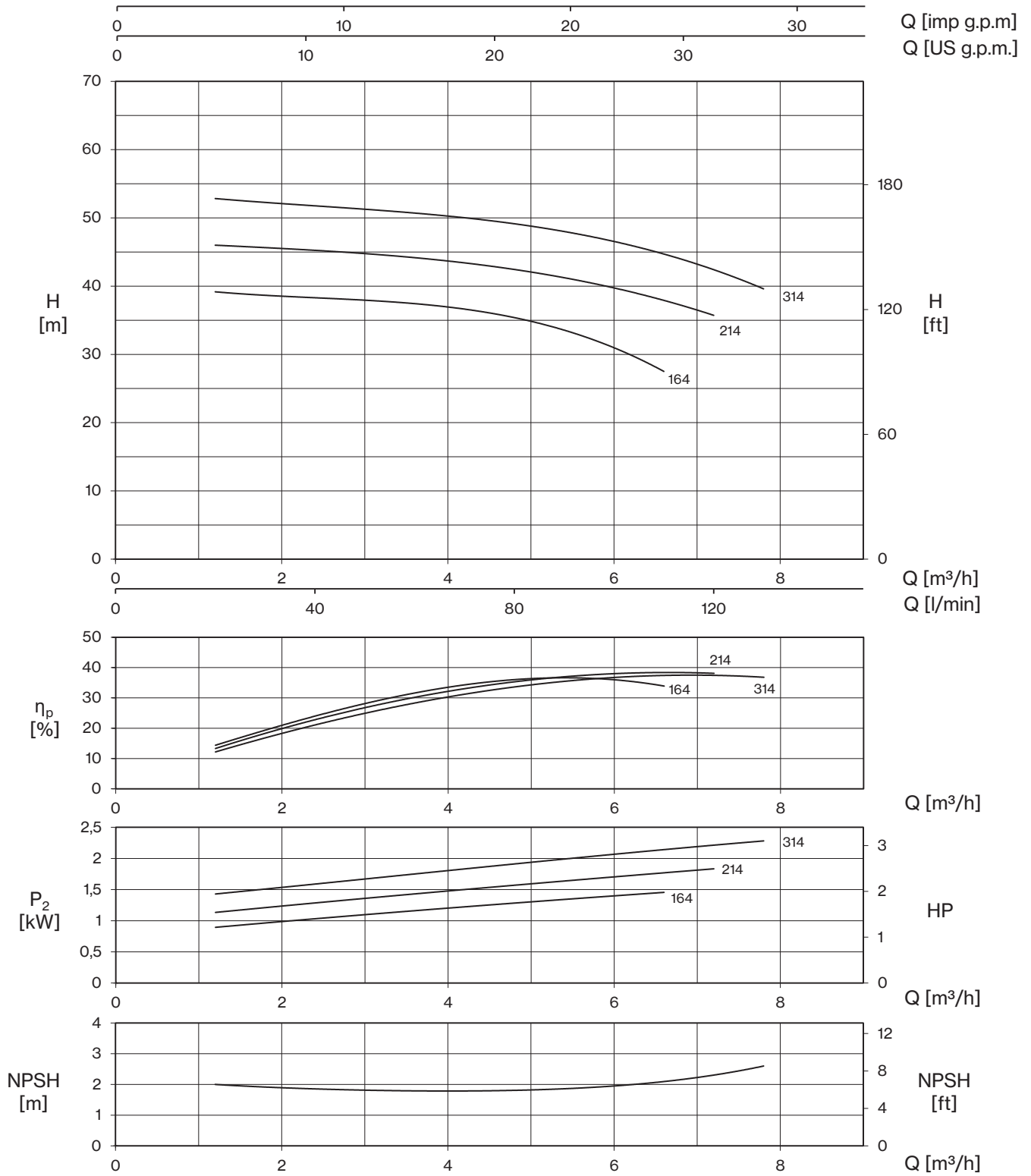

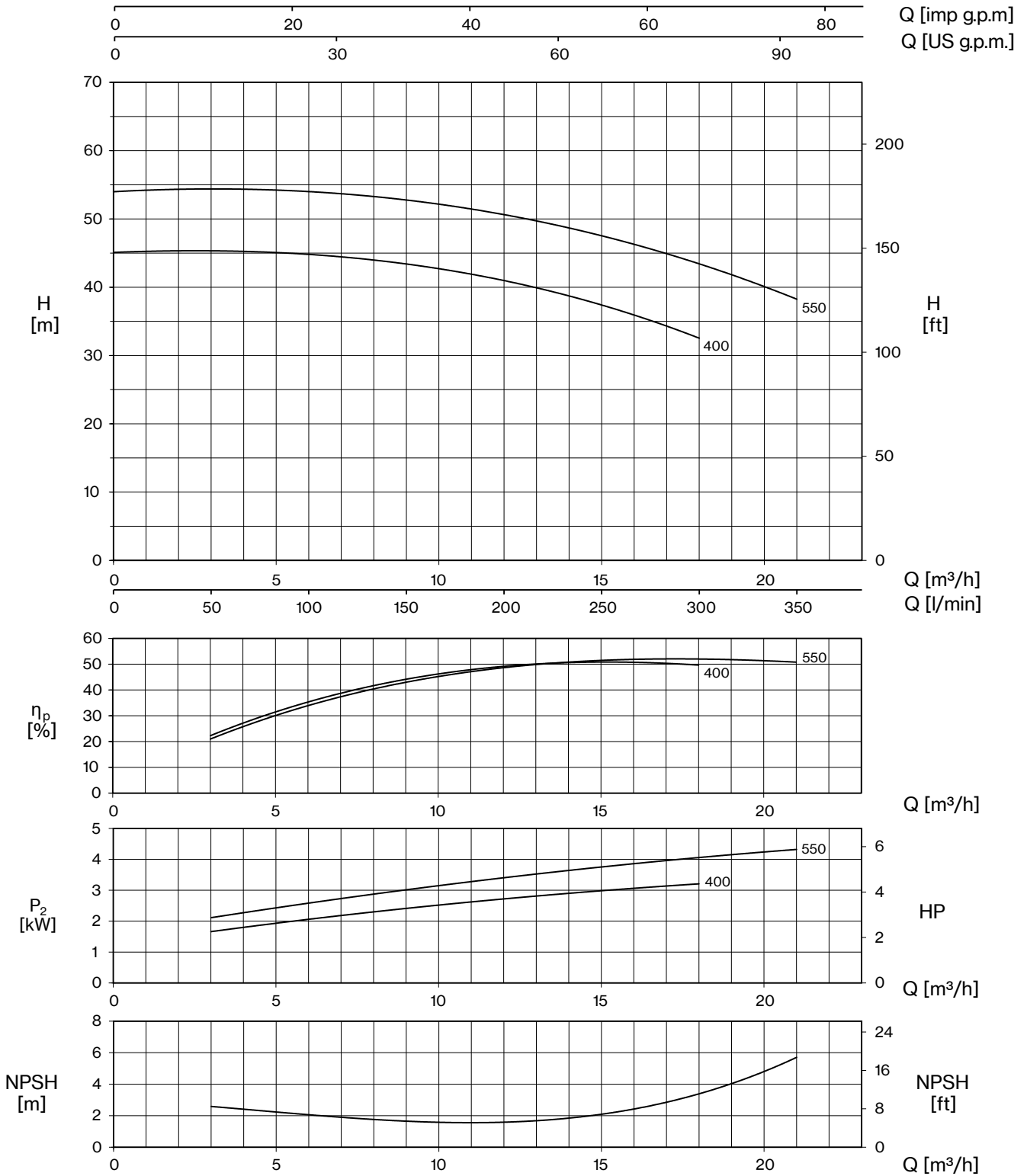

TYPE - 50 Hz		P2		P1		CURRENT		Q (m³/h - l/min)								
1-	3-			1-	3-	1- 230V	3- 400V	0	1,2	2,4	3,6	4,8	6	6,6	7,2	7,8
		HP	kW	kW		A		H (m)								
KM 164	KM 164T	2	1,5	1,8	1,8	8,2	3,7	39,4	39,1	38,6	37,2	35,2	31,5	27,2		
KM 214	KM 214T	2,5	1,85	2,3	2,2	10,4	4,4	46,3	45,9	45,5	44,1	42,1	39,8	38,2	35,5	
KM 314	KM 314T	3	2,2	2,8	2,6	13,0	5,2	53,2	52,7	52,1	50,8	48,8	46,3	45,0	42,9	39,2

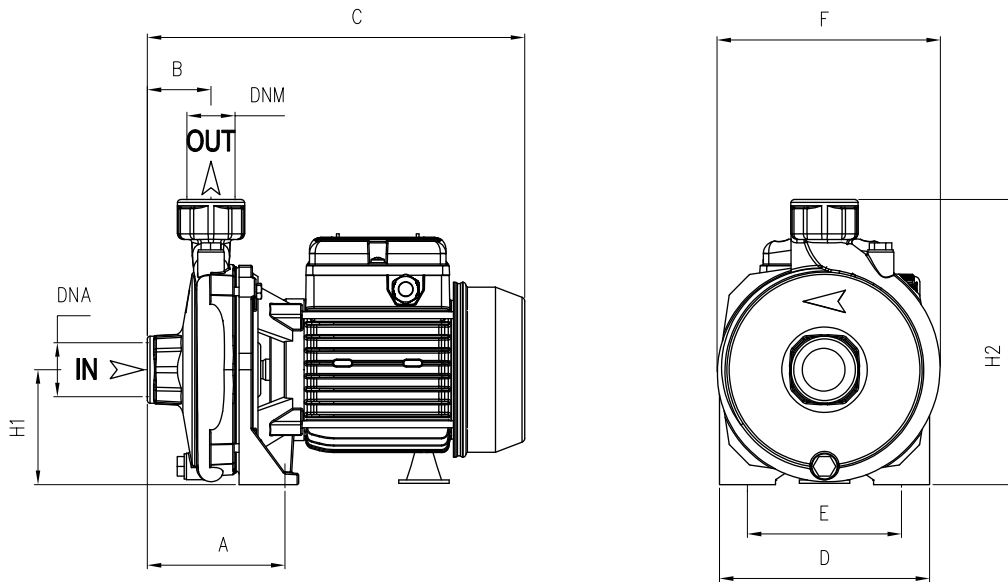

TYPE - 50 Hz		P2		P1		CURRENT		Q (m³/h - l/min)							
1-	3-			1-	3-	1- 230V	3- 400V	0	3	6	9	12	15	18	21
		HP	kW	kW		A		H (m)							
KM 400	KM 400T	4	3	3,6	3,7	16,0	6,7	45,1	45,2	44,9	43,4	40,9	37,4	32,5	
-	KM 550T	5,5	4	-	4,9	-	9,0	54,1	54,1	54,0	52,9	50,7	47,5	43,2	38,4

KM



TYPE		DIMENSIONS (mm)														
-1	-3	A	B	C	D	E	F	H1	H2	DNA	DNM	I	L	M	-1	-3
KM 45	KM 45T	95	45,5	265	150	110	160	82	202	1" G	1" G	290	175	225	8,5	8,5
KM 50	KM 50T	95	45,5	265	150	110	160	82	202			290	170	230	9,5	9,5
KM 86	KM 86T	110	46,5	300	180	140	185	97	234	1" G	1" G	325	200	265	13,5	13
KM 106V	-	110	46,5	300	180	140	185	97	234			325	200	265	14	-
KM 106	KM 106T	110	46,5	300	180	140	185	97	234	1" ¼ G	1" G	420	230	309	25,5	26,5
KM 164	KM 164T	117	46,5	378	220	180	225	115	285			420	230	309	26,5	25,5
KM 214	KM 214T	117	46,5	378	220	180	225	115	285	1" ¼ G	1" G	520	235	320	34,5	-
KM 314	-	117	46,5	446	220	180	225	115	285			420	230	309	-	27
-	KM 314T	117	46,5	378	220	180	225	115	285	2" G	1" ¼ G	480	255	342	46	41,5
KM 400	KM 400T	108	54	460	240	190	250	133	323			480	255	342	-	45,5
-	KM 550T	108	54	460	240	190	250	133	323							