

PRIOX XS

DIRTY WATER DRENA-LINE



- Automatic airventing
- Completely in stainless steel
- Large free passage
- SiC mechanical seal
- Thermal protection build in motor winding

DESCRIPTION

The PLOX XS series pumps are made completely with stainless steel AISI 304. They operate completely immersed in the liquid to be pumped which provides for the cooling of the motor from the outside. Made with a retreated impeller on the principle of vortex operation. Automatic version equipped with float switch.

APPLICATIONS

- All lifting and emptying operations of dirty water with suspended solids.
- Lifting stations with one or more pumps for agricultural and civil use.
- Suitable for the emptying of infiltrated water.
- Handling of dirty discharge water (toilets), emptying of wells and discharge in sewers.

PERFORMANCE

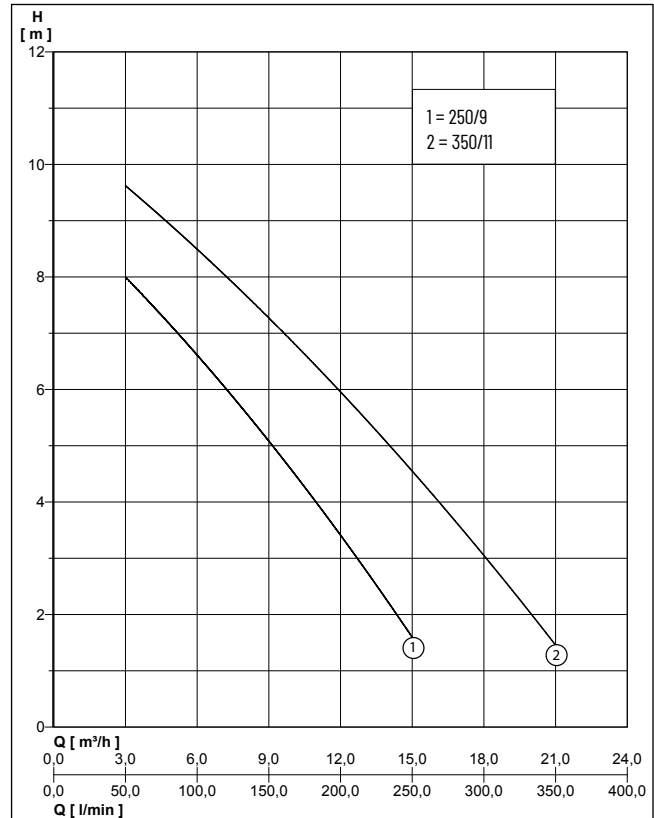

Type	Delivery head H [m]	2	3	4	5	6	7	8	9	10
PRIOX 250/9 XS AUT	Flow rate Q [m³/h]	14.2	12.3	10.5	9.0	6.6	4.5	3.0		
PRIOX 350/11 XS AUT		20.0	18.0	16.0	14.0	12.0	9.8	7.3	4.6	2.0

PRIOX XS

DIRTY WATER DRENA-LINE

MECHANICAL DATA

Free passage	40 mm	Pump housing	Stainless steel X5 CrNi 1810 (AISI 304)
Bearing	Self-lubricating ball bearings.	Mechanical seal	Silicon carbide
Oil chamber	Yes	Counterface	Silicon carbide. Lubricated in oil chamber.
Shaft	Stainless steel X5 CrNiS 1809 (AISI 416)	Type of liquid	discharge water with solids
Impeller	Stainless steel X5CrNi18-10 (AISI 304)	Temperature of the liquid max.	40 °C
		Diving depth	7 m

ELECTRICAL DATA

Voltage	1/N/PE~230 V	Insulation class	F
Power line	10m H07RN-F	Rotation speed	2850 rpm
Type of enclosure	IP 68		

PRIOX XS

Type	Code No.	Motor rating		Current	Weight
		P1	P2		
PRIOX 250/9 XS AUT	N2091210	0.9 kW	0.6 kW	4.1 A	9.8 kg
PRIOX 350/11 XS AUT	N2091220	1.3 kW	0.9 kW	5.8 A	11.2 kg

PRIOX XS AUT

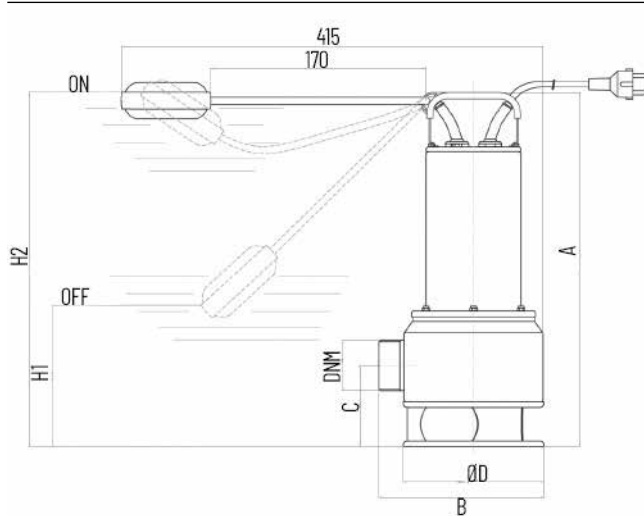

DIMENSIONS [mm]

Type	A	B	C	D	H1	H2	DNM
PRIOX 250/9 XS AUT	389	196	96	168	250	370	1 1/2" GAS
PRIOX 350/11 XS AUT	419	196	96	168	300	400	2" GAS