

# JA 150-300

Self-priming



Self-priming centrifugal pumps for water supply (also mixed with air) of small and medium domestic and civil installations, that can be connected to an autoclave tank.

## Construction features

<b>Pump body</b>	cast iron
<b>Motor bracket</b>	cast iron
<b>Impeller</b>	Noryl® or brass
<b>Mechanical seal</b>	ceramic-graphite-NBR
<b>Motor shaft</b>	stainless steel AISI 303 hydraulic side
<b>Liquid temperature</b>	0 - 50 °C
<b>Operating pressure</b>	max 8 bar

## Motor

	3~ 230/400V - 50Hz
<b>2 Poles induction motor</b>	1~ 230V - 50Hz (with thermal protection)
<b>Insulation class</b>	F
<b>Protection degree</b>	IPX4

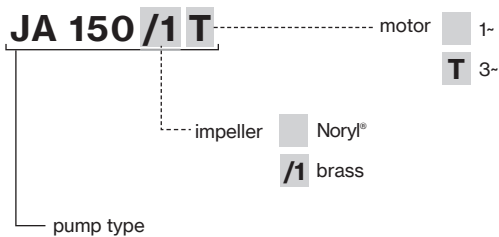

TYPE	LOTS			
	TRUCK		CONTAINER	
	PALLET (cm)	N° pumps	PALLET (cm)	N° pumps
<b>JA 150-300</b>	85×110×140	30	85×110×190	42



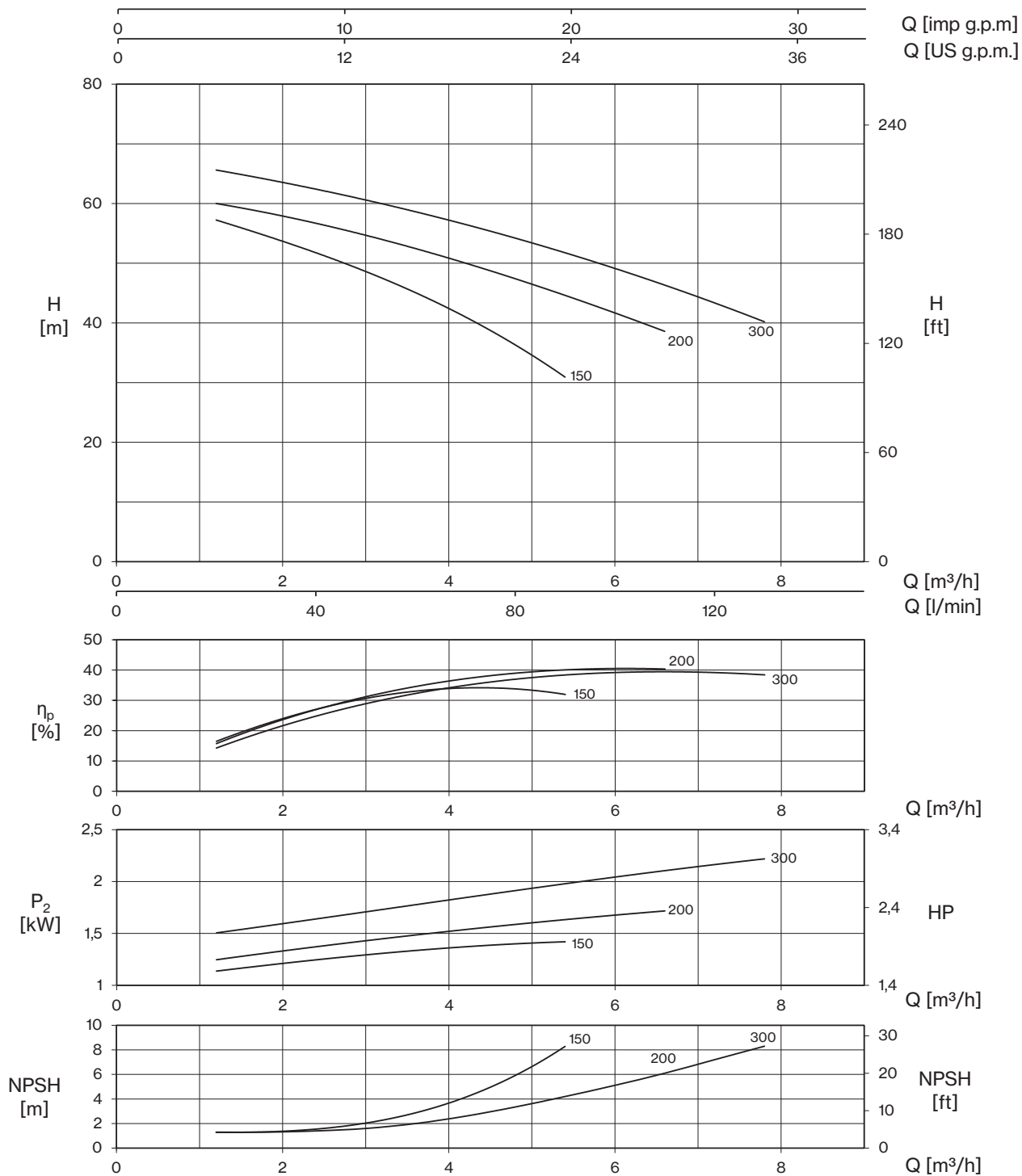

# JA 150-300

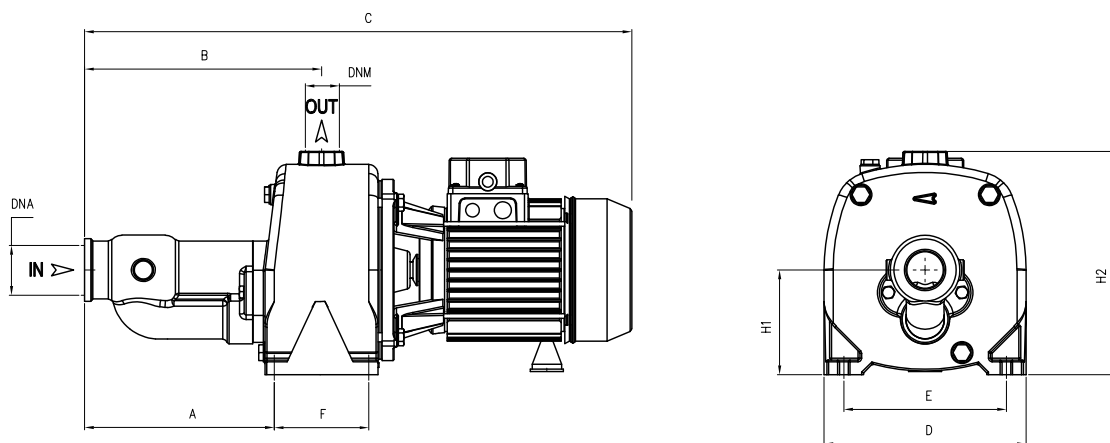

TYPE - 50 Hz		P2		P1		CURRENT		Q (m³/h - l/min)								
1-	3-			1-	3-	1- 230V	3- 400V	0	1,2	1,8	3	4,2	5,4	6,6	7,8	
		HP	kW	kW		A		0	20	30	50	70	90	110	130	
		H (m)														
JA 150	JA 150T	2	1,5	1,8	1,7	8,2	3,6	61,5	57,2	54,7	48,5	40,9	30,8			
JA 200	JA 200T	2,5	1,85	2,2	2,1	9,9	4,3	62,8	60,0	58,5	54,7	50,1	44,5	38,7		
JA 300	JA 300T	3	2,2	2,8	2,6	13,0	5,2	68,4	65,6	64,0	60,7	56,5	51,7	46,4	40,2	



TYPE		DIMENSIONS (mm)													 Kg	
-1	-3	A	B	C	D	E	F	H1	H2	DNA	DNM	I	L	M	-1	-3
JA 150	JA 150T	204	257	626	220	177	105	112	240	1" 1/2 G	1" G	638	230	255	33	34
JA 200	JA 200T	204	257	626	220	177	105	112	240			638	230	255	32,5	33
JA 300	-	204	257	696	220	177	105	112	240			777	259	280	42	-
-	JA 300T	204	257	626	220	177	105	112	240			638	230	255	-	34