

JA 150-300

Self-priming



Self-priming centrifugal pump for water supplies (even if mixed with gas) in small and medium household and civil systems; when connected to autoclave tanks, an automatic pressurisation system comes.

Construction features

Pump body	cast iron
Motor bracket	cast iron
Impeller	Noryl® or brass
Mechanical seal	ceramic-graphite-NBR
Motor shaft	stainless steel AISI 303 hydraulic side
Liquid temperature	0 - 50 °C
Operating pressure	max 8 bar

Motor

	3~ 230/400V-50Hz
2 Poles induction motor	1~ 230V-50Hz (with thermal protection)
Insulation class	F
Protection degree	IPX4

JA 150/1T

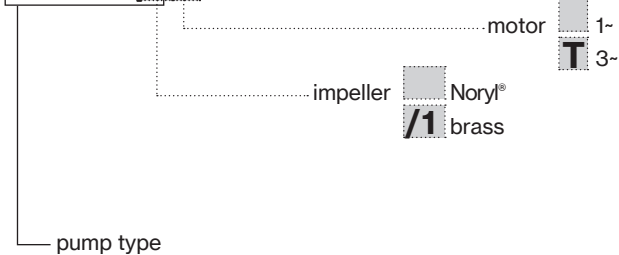

TYPE	LOTS			
	TRUCK		CONTAINER	
	PALLET (cm)	N° pumps	PALLET (cm)	N° pumps
JA 150-300	85x110x140	30	85x110x190	42



JA 150-300

Q [imp g.p.m]

Q [US g.p.m.]

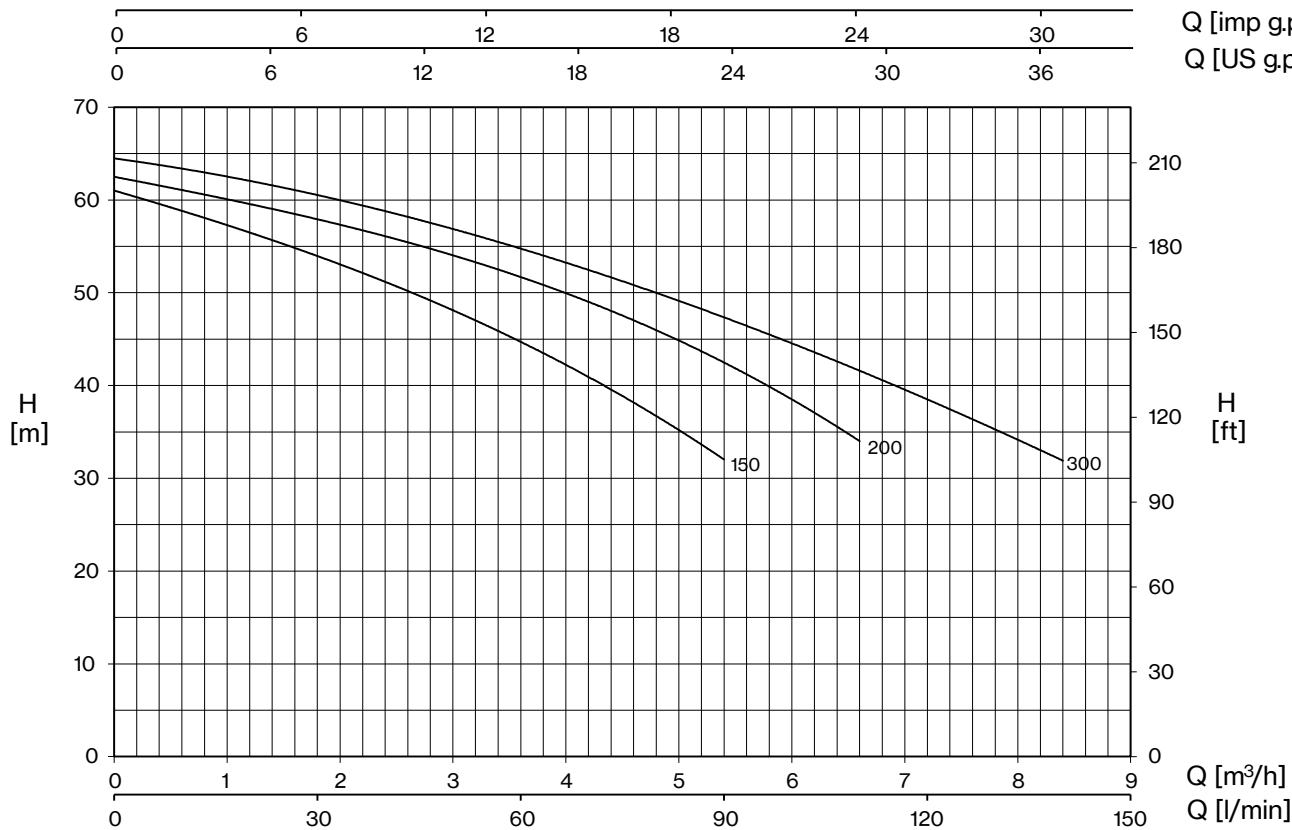

TYPE		P2		P1 (kW)		AMPERE		Q (m³/h - l/min)									
1~	3~	HP	kW	1~	3~	1x230 V 50 Hz	3x400 V 50 Hz	0	1,2	1,8	3	4,2	5,4	6,6	7,8	8,4	
								0	20	30	50	70	90	110	130	140	
								H (m)									
JA 150	JA 150 T	1,5	1,1	1,74	1,68	7,9	3,3	61	56,5	54,0	48,0	41,0	32,0				
JA 200	JA 200 T	2	1,5	2,22	2,1	10,3	3,9	62,5	59,5	58,0	54,0	49,0	42,5	34,0			
JA 300	JA 300 T	3	2,2	2,65	2,5	11,8	4,9	64,5	62	60,5	57,0	52,5	47,0	42,0	35,0	32,0	

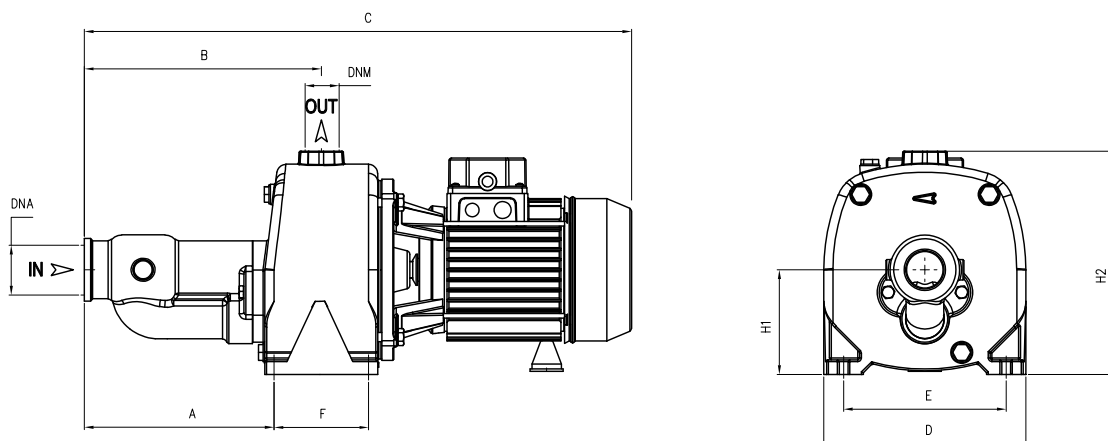

TYPE	DIMENSIONS (mm)													Kg
	A	B	C	D	E	F	H1	H2	DNA	DNM	I	L	M	
JA 150	204	257	596	220	177	105	112	240			610	235	275	30
JA 200	204	257	596	220	177	105	112	240	1" 1/2 G	1" G	610	235	275	30,5
JA 300	204	257	596	220	177	105	112	240			610	235	275	31,5