

# FTR/FTRT

Sewage  
Grinder

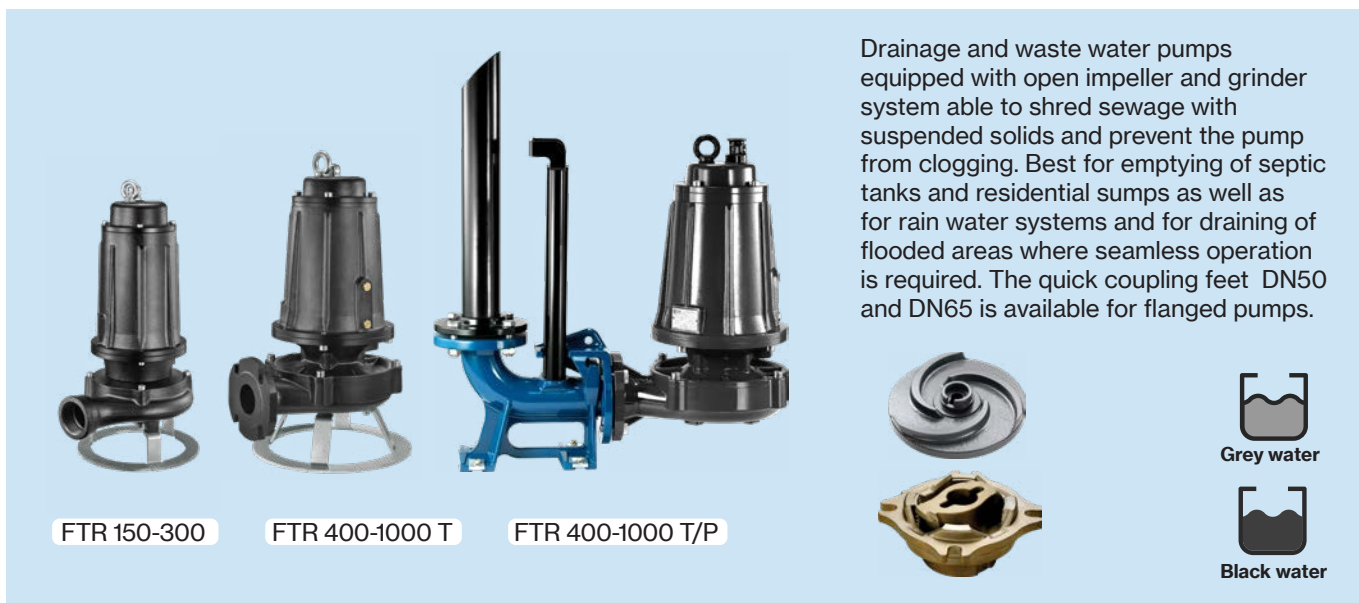

Drainage and waste water pumps equipped with open impeller and grinder system able to shred sewage with suspended solids and prevent the pump from clogging. Best for emptying of septic tanks and residential sumps as well as for rain water systems and for draining of flooded areas where seamless operation is required. The quick coupling feet DN50 and DN65 is available for flanged pumps.

FTR 150-300

FTR 400-1000 T

FTR 400-1000 T/P



Grey water



Black water

## Construction features

<b>Painting</b>	cataphoresis
<b>Pump body</b>	cast iron
<b>Impeller</b>	cast iron
<b>Mechanical seal</b>	double seal with oil barrier: silicon carbide on pump side, ceramic-graphite on motor side
<b>Motor shaft</b>	stainless steel AISI 304
<b>Max submergence</b>	20 m
<b>Liquid temperature</b>	0 - 40 °C
 <b>Grinder</b>	treated stainless steel
<b>Bolts</b>	A2 stainless steel
<b>Foot support</b>	galvanized iron
<b>Gaskets</b>	NBR rubber

## Motor

<b>2 Poles induction motor</b>	3- 230V - 50Hz
	3- 400V - 50Hz
	3- 230/400V - 50Hz
	3- 400/690V - 50Hz
<b>run capacitor</b>	(35µF for 1,5HP models, 50µF for 2HP model) + start capacitor (80µF with disjuntor) required
<b>Insulation class</b>	F
<b>Protection degree</b>	IPX8

TYPE	LOTS		CONTAINER	
	TRUCK		PALLET	
	PALLET (cm)	N° pumps	PALLET (cm)	N° pumps
FTR 150÷300T	85×110×145	18	85×110×190	27
FTR 400-550T	85×110×170	12	85×110×170	12
FTR 1000T	100×120×190	12	100×120×190	12

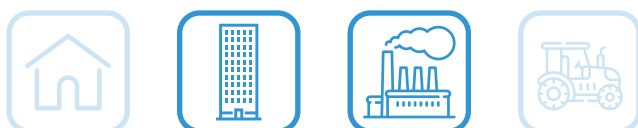
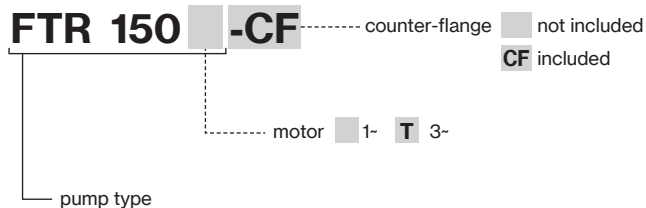

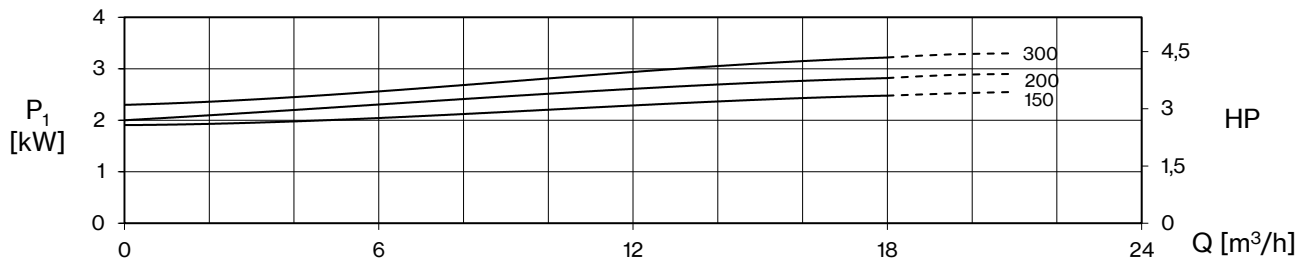
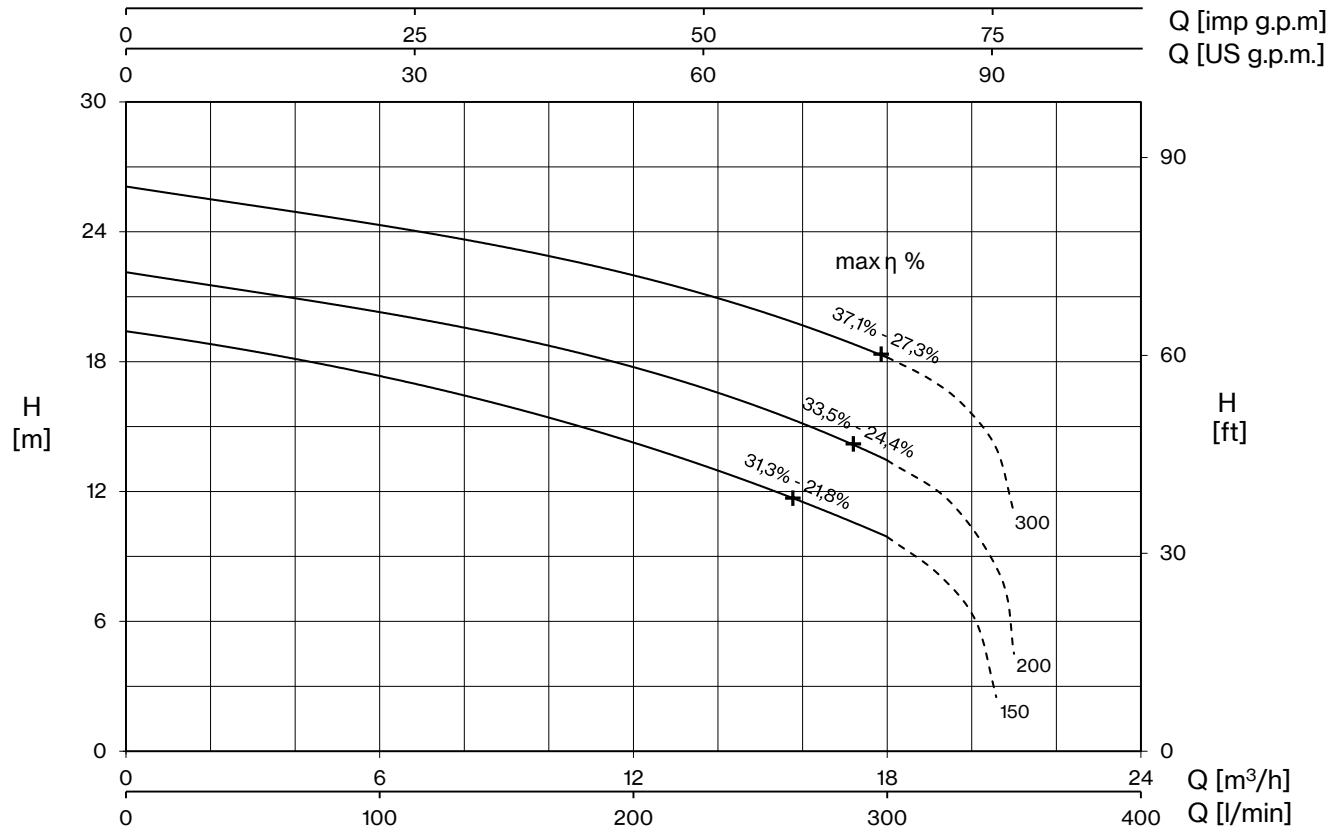

TYPE - 50 Hz		CURRENT				
1~	3~	230 V	3~ 230V (*)	3~ 400V	230/400 V $\lambda / \Delta$ (*)	400/690 V $\lambda / \Delta$
FTR 150	FTR 150T	11,5	7,6	4,4	-	-
FTR 200	FTR 200T	13,6	8,8	5,1	-	-
-	FTR 300T	-	10,0	5,8	-	-

+ max  $\eta$  %

max hydraulic efficiency and respective total efficiency

(\*) no standard execution

TYPE - 50 Hz		P2		P1		Q (m³/h - l/min)							
1~	3~	HP	kW	1~	3~	0	3	6	9	12	13,2	15	18
						0	50	100	150	200	220	250	300
				kW		H (m)							
FTR 150	FTR 150T	1,5	1,1	2,6	2,5	19,4	18,5	17,3	16,0	14,2	13,5	12,3	9,9
FTR 200	FTR 200T	2	1,5	3,0	2,8	22,1	21,3	20,3	19,1	17,7	17,1	16,0	13,4
-	FTR 300T	3	2,2	-	3,2	26,1	25,2	24,3	23,3	22,0	21,4	20,3	18,2

# FTR/FTRT

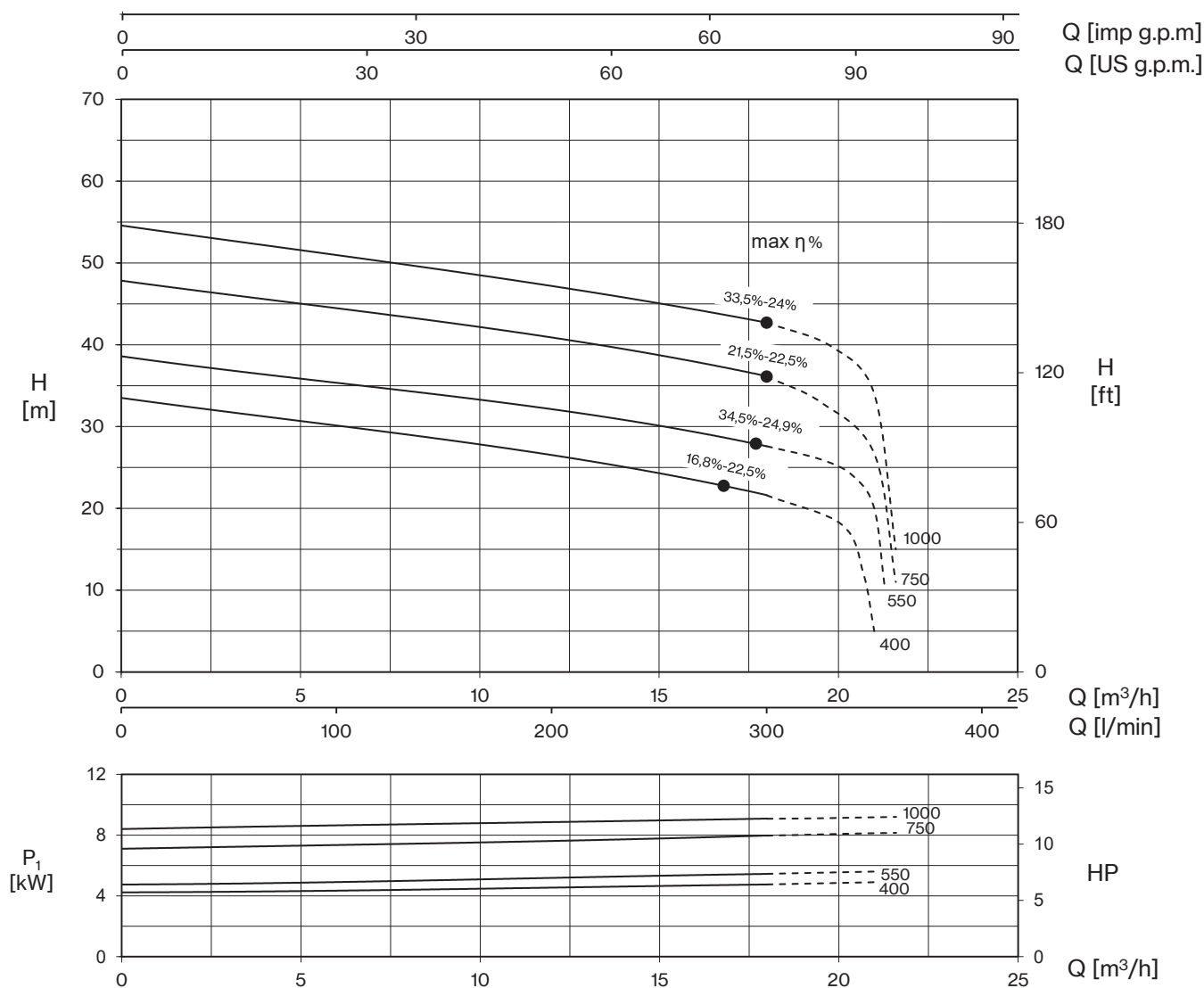

TYPE - 50 Hz	CURRENT			
3~	3- 230V (*)	3- 400V	230/400V λ / Δ (*)	400/690V λ / Δ
<b>FTR 400T</b>	13,0	7,5	-	-
<b>FTR 550T</b>	15,9	9,2	-	-
<b>FTR 750T</b>	-	13,9	24	13,9
<b>FTR 1000T</b>	-	15,5	26,8	15,5

**+ max η %**

max hydraulic efficiency and respective total efficiency

(\*) no standard execution

TYPE - 50 Hz	P2		P1	Q (m³/h - l/min)							
				0	3	6	9	12	15	18	
				0	50	100	150	200	250	300	
3~	HP	kW	kW	H (m)							
<b>FTR 400T</b>	4	3	4,5	33,5	31,8	30,1	28,5	26,4	24,4	21,6	
<b>FTR 550T</b>	5,5	4	5,3	38,6	36,9	35,3	33,9	32,1	30,1	27,6	
<b>FTR 750T</b>	7,5	5,5	8,0	47,8	46,2	44,5	42,7	40,8	38,9	36,1	
<b>FTR 1000T</b>	10	7,5	9,1	54,6	52,7	51,0	49,2	47,1	45,1	42,7	

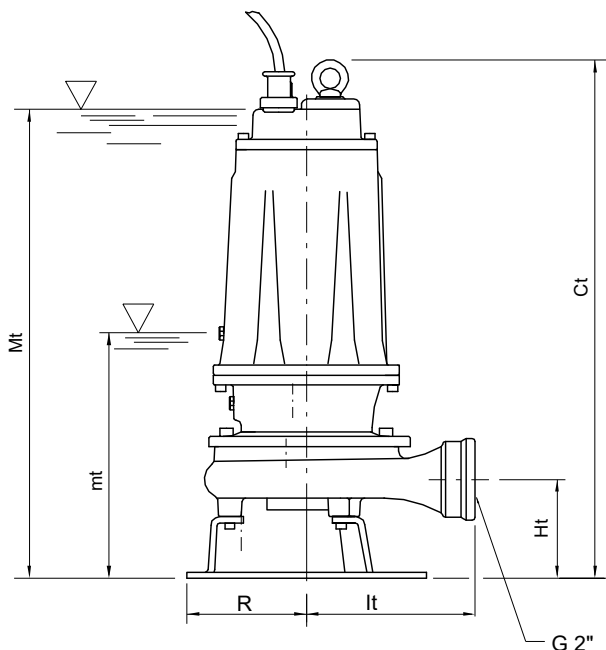

mt: minimum working level  
 Mt: minimum submergence level for continuous duty

TYPE		DIMENSIONS (mm)							Kg
1-	3-	Ct	Ht	R	lt	mt	Mt	DNM	
<b>FTR 150</b>	<b>FTR 150T</b>	513	102	117	174	205	475	2" G	38
<b>FTR 200</b>	<b>FTR 200T</b>	513	102	117	174	205	475	2" G	38,5
-	<b>FTR 300T</b>	513	102	117	174	205	475	2" G	38

TYPE	PROTECTION		1 PUMP CONTROL PANEL			2 PUMPS CONTROL PANEL		
	1- 230V	3- 400V	1- 230V	3- 400V	400/690 V	1- 230V	3- 400V	400/690 V
<b>FTR 150</b>	PMLD 15/35-13	PT 20-30-40/4.3-6.8	EQSM + 35µF + 80µF*	EQSMT 10		EQ2SM + 2×35µF + 2×80µF*	EQ2SMT 10	
<b>FTR 200</b>	PMLD 20/50-15	PT 20-30-40/4.3-6.8	EQSM + 50µF + 80µF*	EQSMT 10		EQ2SM + 2×50µF + 2×80µF*	EQ2SMT 10	
<b>FTR 300T</b>		PT 20-30-40/4.3-6.8		EQSMT 10			EQ2SMT 10	
<b>FTR 400T</b>		PT 40-50/5.7-9.1		EQSMT 10			EQ2SMT 10	
<b>FTR 550T</b>		PT 55-75/8.6-13.5		EQSMT 10			EQ2SMT 10	
<b>FTR 750T</b>		PT 100/12.5-16.5		EQSMT 10	QST 7		EQ2SMT 10	Q2ST 7
<b>FTR 1000T</b>		PT 125-150/16-21		EQSMT 10	QST 10		EQ2SMT 15	Q2ST 10

\*start capacitor with disjuntor

