



Submersible multistage centrifugal pumps for 6" wells, made of solid and sturdy construction. The motor bracket and coupling are made according to NEMA standards: 4" motor up to 7.5 HP, 6" motor above 10 HP.

High-pressure pumps, due to their excessive length, are delivered in separate liquid-ends and can be easily reassembled at the installation site. Common applications include civil and agricultural use. The pump materials are certified for drinking water, and due to their high efficiency and reliability, these pumps are highly recommended for residential, commercial, and agricultural applications.

The pumps are ideal for automatic water distribution in combination with pressure tanks, irrigation systems, and other uses.

Construction features

Suction and delivery outlet	stainless steel AISI 304
External jacket	stainless steel AISI 304
Impellers	polyphenylene oxide
Diffusers	polyphenylene oxide and AISI 304
Support bush with sleeves	stainless steel AISI 316L
Shaft	stainless steel AISI 431B
Coupling	stainless steel AISI 316L
Quantity of sand in the water	150 g/m ³
Max liquid temperature	35 °C



6E 175

50 Hz - 2900 rpm					Q										
TYPE	SUITABLE MOTOR 3- 400V			AXIAL LOAD	l/min	0	100	120	125	150	175	200	225	250	275
	P2		CURRENT			l/sec	0	1,67	2,00	2,08	2,50	2,92	3,33	3,75	4,17
	HP	kW	A	N	m³/h	0	6,0	7,2	7,5	9,0	10,5	12,0	13,5	15,0	16,5
6E 175/05-30	3	2,2	6,2	1410	H (m)	78	67	64	63	58	53	46	37	27	16
6E 175/06-40	4	3	7,8	1690		94	80	77	76	70	63	55	44	32	19
6E 175/07-55	5,5	4	9,9	1970		109	94	90	89	82	74	64	52	38	22
6E 175/08-55	5,5	4	9,9	2250		125	107	103	101	93	84	73	59	43	25
6E 175/09-55	5,5	4	9,9	2530		140	121	115	114	105	95	82	67	48	28
6E 175/12-75	7,5	5,5	13,8	3370		187	161	154	152	140	127	109	89	65	37
6E 175/16-100	10	7,5	16,9	4500		250	214	205	202	187	169	146	118	86	50
6E 175/18-125	12,5	9,3	21,5	5060		281	241	231	228	210	190	164	133	97	56
6E 175/21-125	12,5	9,3	21,5	5900		328	281	269	266	245	222	192	155	113	65
6E 175/24-150	15	11	23,7	6740		374	322	308	304	280	253	219	178	129	74
6E 175/28-175	17,5	13	27,8	7870		437	375	359	354	327	295	255	207	151	87
6E 175/32-200	20	15	30,4	8990		499	429	410	405	374	338	292	237	172	99
6E 175/40-250	25	18,5	38,3	11240		624	536	513	506	467	422	365	296	215	124
6E 175/48-300	30	22	44	13480		749	643	615	607	561	506	438	355	258	149
6E 175/54-400	40	30	62	15170		842	724	692	683	631	570	492	400	291	167

MEI ≥ 0,7 (regulation EU N. 547/2012)

Max Eff. %	68,1
Max kW / St.	0,444

NPSH (m)	Q=25%	Q=50%	Q=75%	Q=100%
	1,1	1,5	2,0	4,5

6E 225

50 Hz - 2900 rpm					Q										
TYPE	SUITABLE MOTOR 3- 400V			AXIAL LOAD	l/min	0	150	175	200	225	250	275	300	325	350
	P2		CURRENT			l/sec	0	2,50	2,92	3,33	3,75	4,17	4,58	5,00	5,42
	HP	kW	A	N	m³/h	0	9,0	10,5	12,0	13,5	15,0	16,5	18,0	19,5	21,0
6E 225/05-40	4	3	7,8	1420	H (m)	79	71	68	64	58	52	45	37	27	15
6E 225/06-55	5,5	4	9,9	1700		94	86	81	76	70	63	54	44	32	17
6E 225/07-75	7,5	5,5	13,8	1980		110	100	95	89	82	73	63	51	37	20
6E 225/08-75	7,5	5,5	13,8	2270		126	114	109	102	93	83	72	58	42	23
6E 225/09-75	7,5	5,5	13,8	2550		141	128	122	115	105	94	81	66	48	26
6E 225/12-100	10	7,5	16,9	3400		188	171	163	153	140	125	108	88	64	35
6E 225/15-125	12,5	9,2	21,5	4240		236	214	204	191	175	156	135	110	80	44
6E 225/18-150	15	11	23,7	5090		283	257	244	229	210	188	162	131	95	52
6E 225/21-175	17,5	13	27,8	5940		330	299	285	267	245	219	189	153	111	61
6E 225/24-200	20	15	30,4	6790		377	342	326	306	280	250	216	175	127	70
6E 225/30-250	25	18,5	38,3	8480		471	428	407	382	350	313	269	219	159	87
6E 225/35-300	30	22	44	9900		550	499	475	446	408	365	314	256	186	102
6E 225/40-400	40	30	62	11310		628	570	543	509	466	417	359	292	212	116
6E 225/45-400	40	30	62	12720		707	641	611	573	524	469	404	329	239	131
6E 225/52-500	50	37	72	14700		816	741	706	662	606	542	467	380	276	151

MEI ≥ 0,7 (regulation EU N. 547/2012)

Max Eff. %	69,6
Max kW / St.	0,637

NPSH (m)	Q=25%	Q=50%	Q=75%	Q=100%
	1,1	1,4	3,2	6,9



6E

6E 350

50 Hz - 2900 rpm					Q											
TYPE	SUITABLE MOTOR 3~ 400V			AXIAL LOAD	l/min	0	225	250	275	300	350	400	450	500	550	600
	P2		CURRENT			l/sec	0	3,75	4,17	4,58	5,00	5,83	6,67	7,50	8,33	9,17
	HP	kW	A	N	m³/h	0	13,5	15,0	16,5	18,0	21,0	24,0	27,0	30,0	33,0	36,0
6E 350/02-20	2	1,5	4,6	790	H (m)	28	23	22	21	20	18	15	13	10	7	4
6E 350/03-30	3	2,2	6,2	1180		42	34	33	32	30	27	23	19	15	10	5
6E 350/04-40	4	3	7,8	1570		56	46	44	42	40	36	31	26	20	14	7
6E 350/05-55	5,5	4	9,9	1960		70	57	55	53	50	45	39	32	25	17	9
6E 350/07-75	7,5	5,5	13,8	2750		98	80	77	74	70	62	54	45	35	24	13
6E 350/10-100	10	7,5	16,9	3920		140	114	110	105	100	89	77	64	50	34	18
6E 350/12-125	12,5	9,3	21,5	4700		168	137	131	126	120	107	93	77	60	41	22
6E 350/15-150	15	11	23,7	5880		210	171	164	158	150	134	116	96	75	51	27
6E 350/17-175	17,5	13	27,8	6660		238	194	186	179	170	152	131	109	85	58	31
6E 350/20-200	20	15	30,4	7840		280	228	219	210	200	178	154	128	100	69	36
6E 350/25-250	25	18,5	38,3	9800		350	285	274	263	250	223	193	160	125	86	45
6E 350/30-300	30	22	44	11760		420	342	329	315	300	268	232	192	149	103	54
6E 350/35-400	40	30	62	13720		490	399	383	368	350	312	270	224	174	120	63
6E 350/40-400	40	30	62	15680		560	456	438	420	400	357	309	256	199	137	72
6E 350/50-500	50	37	72	19600		700	571	548	525	500	446	386	320	249	172	90

MEI ≥ 0,4 (regulation EU N. 547/2012)

Max Eff. %	69,1
Max kW / St.	0,75

NPSH (m)	Q=25%	Q=50%	Q=75%	Q=100%
	1,2	1,6	2	4,8

6E 400

50 Hz - 2900 rpm					Q											
TYPE	SUITABLE MOTOR 3~ 400V			AXIAL LOAD	l/min	0	300	325	350	375	400	450	500	550	600	650
	P2		CURRENT			l/sec	0	5,00	5,42	5,83	6,25	6,67	7,50	8,33	9,17	10,00
	HP	kW	A	N	m³/h	0	18,0	19,5	21,0	22,5	24,0	27,0	30,0	33,0	36,0	39,0
6E 400/03-40	4	3	7,8	1290	H (m)	46	35	34	32	31	29	25	21	16	10	4
6E 400/04-55	5,5	4	9,9	1720		61	47	45	43	41	39	33	27	21	13	5
6E 400/06-75	7,5	5,5	12,5	2570		92	70	68	65	61	58	50	41	31	20	8
6E 400/08-100	10	7,5	16,9	3430		122	94	90	86	82	77	67	55	42	27	11
6E 400/10-125	12,5	9,3	21,5	4290		153	117	113	108	102	97	84	69	52	34	14
6E 400/12-150	15	11	23,7	5150		184	141	135	129	123	116	100	82	63	40	16
6E 400/14-175	17,5	13	27,8	6000		214	164	158	151	143	135	117	96	73	47	19
6E 400/16-200	20	15	30,4	6860		245	187	180	172	164	154	134	110	83	54	22
6E 400/20-250	25	18,5	38,3	8570		306	234	225	215	205	193	167	137	104	67	27
6E 400/24-300	30	22	44	10290		367	281	270	258	246	232	200	164	125	81	32
6E 400/28-400	40	30	62	12000		428	328	315	301	287	270	234	192	146	94	38
6E 400/32-400	40	30	62	13710		490	375	360	344	328	309	267	219	167	108	43
6E 400/40-500	50	37	72	17140		612	468	450	430	410	386	334	274	208	134	54

MEI ≥ 0,4 (regulation EU N. 547/2012)

Max Eff. %	67,8
Max kW / St.	0,94

NPSH (m)	Q=25%	Q=50%	Q=75%	Q=100%
	1,2	1,6	2,3	5,0

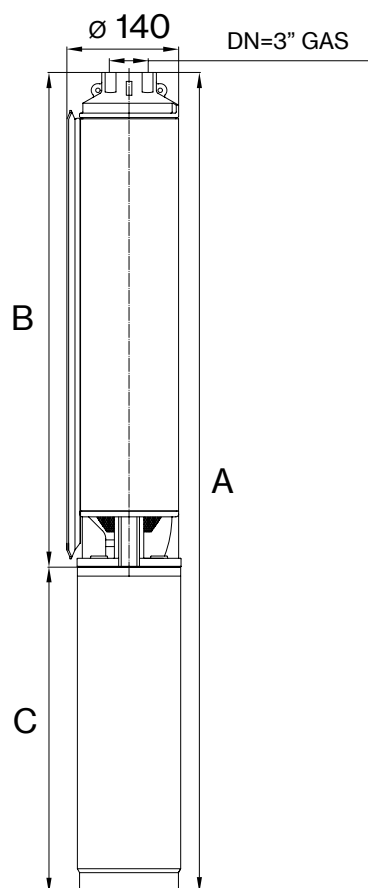

6E 175

TYPE	MOTOR BRACKET	DIMENSIONS (mm)			WEIGHT (kg)		
		A	B	C	A	B	C
6E 175/05-30-4	4" NEMA	898	478	420	21,8	9,8	12
6E 175/06-40-4		934	516	418	23,2	10,4	12,8
6E 175/07-55-4		1022	554	468	26,4	11,1	15,3
6E 175/08-55-4		1060	592	468	27,1	11,8	15,3
6E 175/09-55-4		1098	630	468	27,7	12,4	15,3
6E 175/12-75-4		1282	744	538	33,3	14,4	18,9
6E 175/16-100	6" NEMA	1458	858	600	58,9	16,9	42
6E 175/18-125		1572	972	600	63,3	18,3	45
6E 175/21-125		1686	1086	600	67,2	22,2	45
6E 175/24-150		1900	1200	700	72,2	24,2	48
6E 175/28-175		2104	1404	700	77,7	27,7	50
6E 175/32-200*		2453	1693	760	95	41	54
6E 175/40-250*		2827	1997	830	112,5	47,5	65
6E 175/48-300*		3191	2301	890	124,1	54,1	70
6E 175/54-400*	3559	2529	1030	149	59	90	

* Pump supplied in separate liquid ends

6E

6E 225

TYPE	MOTOR BRACKET	DIMENSIONS (mm)			WEIGHT (kg)		
		A	B	C	A	B	C
6E 225/05-40-4	4" NEMA	896	478	418	22,6	9,8	12,8
6E 225/06-55-4		984	516	468	25,8	10,5	15,3
6E 225/07-75-4		1092	554	538	29,7	11,1	18,6
6E 225/08-75-4		1130	592	538	30,4	11,8	18,6
6E 225/09-75-4		1168	630	538	31	12,4	18,6
6E 225/12-100	6" NEMA	1344	744	600	56,3	14,3	42
6E 225/15-125		1458	858	600	61,3	16,3	45
6E 225/18-150		1672	972	700	66,2	18,2	48
6E 225/21-175		1786	1086	700	72,2	22,2	50
6E 225/24-200		1960	1200	760	78,1	24,1	54
6E 225/30-250		2310	1480	830	93,9	28,9	65
6E 225/35-300*		2697	1807	890	113,1	43,1	70
6E 225/40-400*		3027	1997	1030	137,2	47,2	90
6E 225/45-400*		3217	2187	1030	141,3	51,3	90
6E 225/52-500*		3623	2453	1170	158	57	101

* Pump supplied in separate liquid ends

6E 350

TYPE	MOTOR BRACKET	DIMENSIONS (mm)			WEIGHT (kg)		
		A	B	C	A	B	C
6E 350/02-20-4	4" NEMA	786	401	385	17,8	7,4	10,4
6E 350/03-30-4		878	458	420	20,3	8,3	12
6E 350/04-40-4		933	515	418	22	9,2	12,8
6E 350/05-55-4		1040	572	468	25,3	10	15,3
6E 350/07-75-4		1224	686	538	30,7	11,8	18,9
6E 350/10-100	6" NEMA	1457	857	600	56,3	14,3	42
6E 350/12-125		1571	971	600	61,1	16,1	45
6E 350/15-150		1842	1142	700	66,7	18,7	48
6E 350/17-175		2008	1308	700	71,2	21,2	50
6E 350/20-200		2254	1494	760	79,9	25,9	54
6E 350/25-250		2608	1778	830	95,3	30,3	65
6E 350/30-300*		3077	2187	890	119,1	49,1	70
6E 350/35-400*		3502	2472	1030	144,7	54,7	90
6E 350/40-400*		3891	2861	1030	152,5	62,5	90
6E 350/50-500*		4601	3431	1170	174,7	73,7	101

* Pump supplied in separate liquid ends

6E 400

TYPE	MOTOR BRACKET	DIMENSIONS (mm)			WEIGHT (kg)		
		A	B	C	A	B	C
6E 400/03-40-4	4" NEMA	877	459	418	22,6	9,8	12,8
6E 400/04-55-4		984	516	468	26,1	10,8	15,3
6E 400/06-75-4		1200	630	570	52,9	12,9	40
6E 400/08-100	6" NEMA	1344	744	600	56,9	14,9	42
6E 400/10-125		1458	858	600	62,1	17,1	45
6E 400/12/150		1672	972	700	67,2	19,2	48
6E 400/14-175		1786	1086	700	71,4	21,4	50
6E 400/16-200		1960	1200	760	77,4	23,4	54
6E 400/20-250		2310	1480	830	92,7	27,7	65
6E 400/24-300		2597	1707	890	101,5	31,5	70
6E 400/28-400*		3103	2073	1030	136,9	46,9	90
6E 400/32-400*		3331	2301	1030	141,2	51,2	90
6E 400/40-500*		3927	2757	1170	160,8	59,8	101
6E 400/46-600*	-	3099	-	-	66,3	-	

* Pump supplied in separate liquid ends

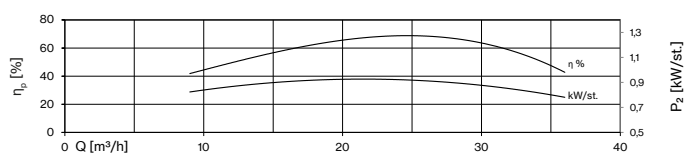
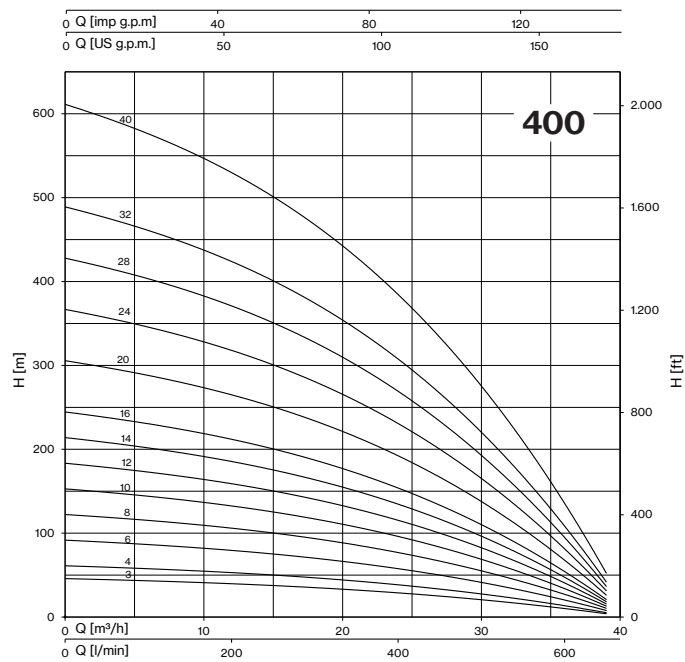
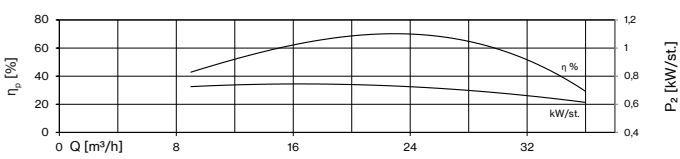
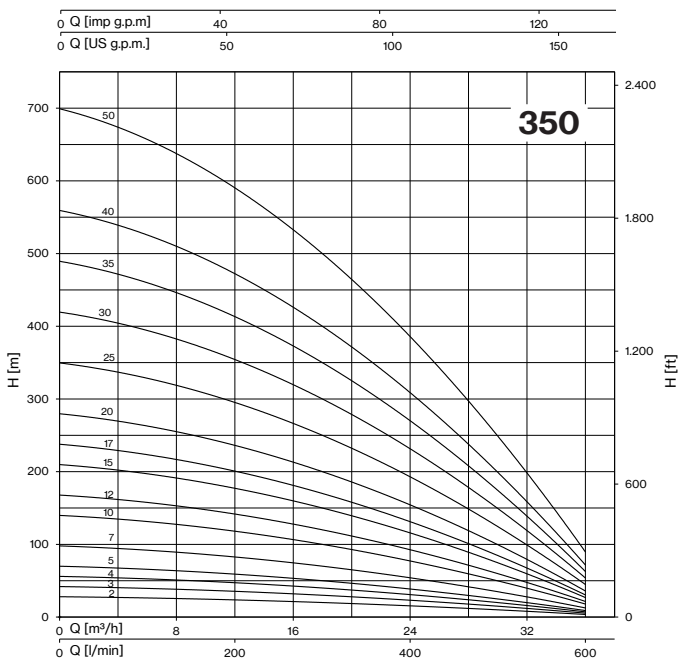
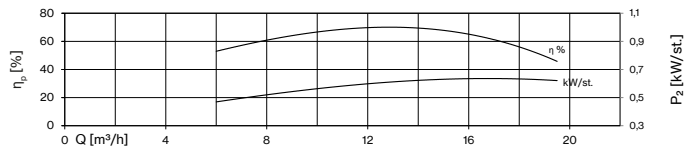
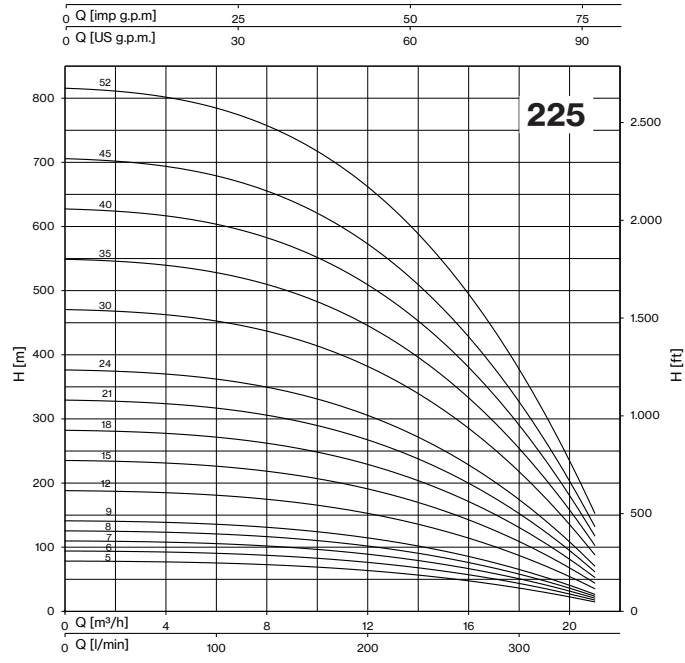
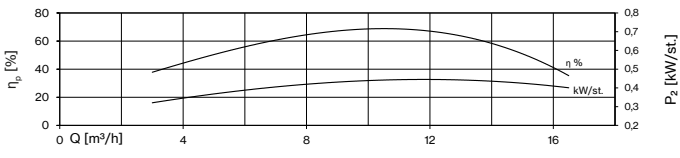
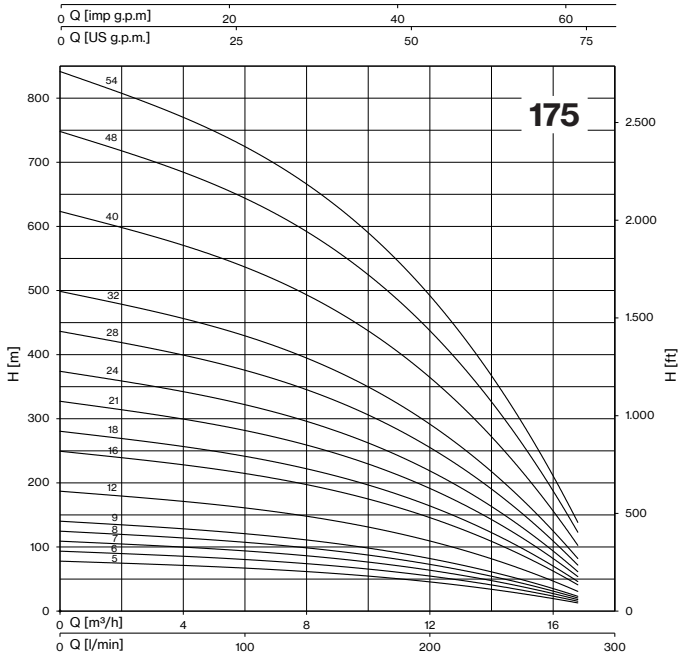

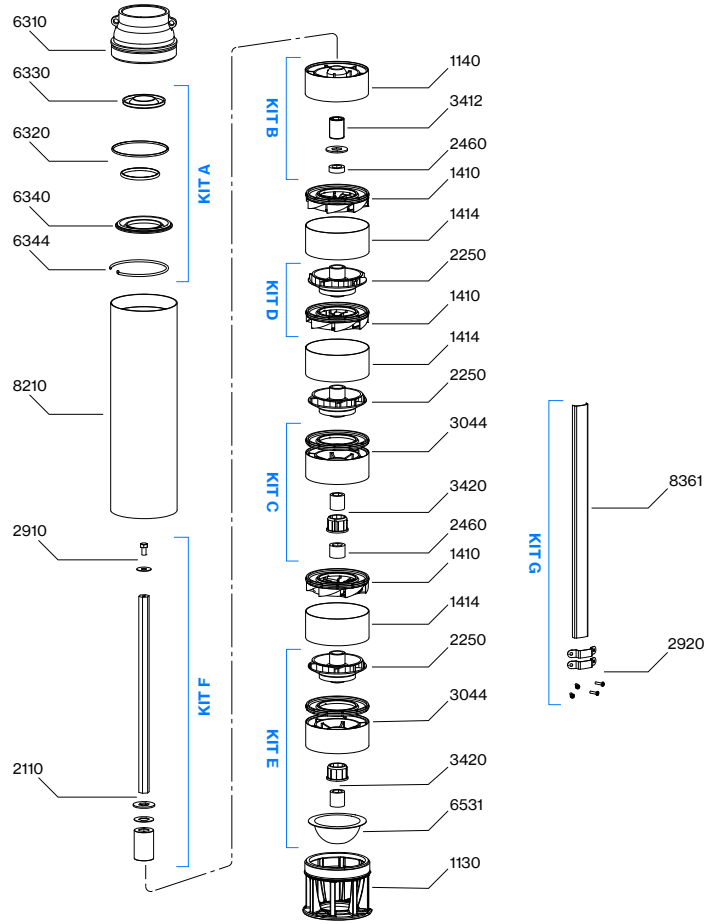

N. CODE	KIT	DESCRIPTION	MATERIAL
6320	KIT A <i>check valve</i>	O-RINGS	NBR
6330		WING VALVE	AISI 304
6340		WING VALVE SUPPORT	AISI 304
6344		SEEGER	AISI 304
1140	KIT B <i>upper support</i>	UPPER SUPPORT	PPO + PA
2460		SPACER SLEEVE	PPO
3412		SUPPORT SLEEVE	AISI 316L + CERAMIC
2460	KIT C <i>intermediate support</i>	WASHER AND SPACERS	PPO
3044		SUPPORT WITH BUSH AND DISC	PPO + PA
3420		SUPPORT SLEEVE WITH SPACERS	AISI 316L
1410	KIT D <i>stage</i>	COMPLETE DIFFUSER	PPO + AISI 304
2250		IMPELLER	PPO
2250	KIT E <i>first stage</i>	FIRST IMPELLER	PPO
3044		SUPPORT WITH BUSH AND DISC	PPO + PA
3420		SUPPORT SLEEVE WITH SPACERS	AISI 316L
6531		GRID	AISI 304
2110	KIT F <i>shaft with coupling</i>	SHAFT WITH COUPLING	AISI 431B + AISI 316
2910		SCREW WITH WASHER	AISI 304
2920	KIT G <i>cover cable</i>	2× SCREW AND CLIP	AISI 304
8361		CABLE COVER	AISI 304
1130	-	BOTTOM CASING	AISI 304
1414		SPACER PIPE	AISI 304
6310		TOP CASING	AISI 304
8210		EXTERNAL PIPE	AISI 304