

# PLUS SV/SL/SLX

## Multistage Vertical

Stainless steel multistage vertical pumps. Pumping of clean non-loaded fluids, pressurizing system, irrigation, drinking and glycol water, water treatment, food industry, heating and air conditioning, washing system.

### Construction features

<b>Pump body</b>	cast iron (SV/SL); stainless steel AISI 304 (SLX)
<b>Motor bracket</b>	cast iron
<b>Impellers, diffusers, shell, motor shaft</b>	stainless steel AISI 304
<b>Mechanical seal</b>	ceramic-graphite-EPDM graphite-silicon carbide-EPDM
<b>Intermediate shaft guiding stage bush</b>	ceramic-tungsten carbide
<b>Ambient temperature</b>	max 40 °C
<b>Liquid temperature</b>	+5 ÷ 90 °C (SV) -15 ÷ 110 °C (SL/SLX)
<b>Max operating pressure</b>	8 bar ≤ 6 impellers 14 bar ≥ 7 impellers
<b>Pump body gasket</b>	EPDM

### Motor

<b>2 poles induction motor</b>	3~ 230/400V - 50Hz P ≤ 4kW 3~ 400/690V - 50Hz P > 4kW 1- 230V-50Hz (with thermal protection up to 1,85 kW)
<b>Insulation class</b>	F
<b>Protection degree</b>	IPX4 IPX5 ≥ 4,5 HP

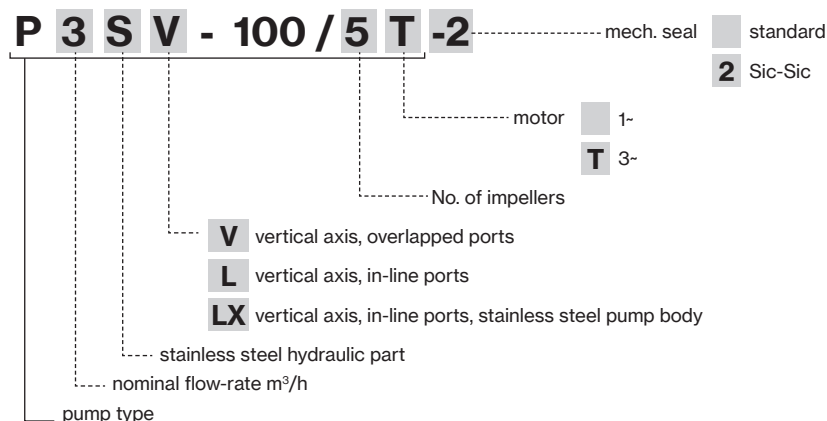

PLUS SV



PLUS 3-5-7 SL



PLUS 9-18 SL



PLUS SLX



# PLUS SV/SL/SLX

TYPE - 50 Hz		P2		P1		CURRENT		Q (m³/h - l/min)						
1-	3-			1-	3-	1- 230V	3- 400V	0	0,6	1,2	1,8	2,4	3,6	4,8
								0	10	20	30	40	60	80
		HP	kW	kW		A								
P 3...-100/5	P 3...-100/5T	1	0,75	1	0,9	4,4	1,7	55,3	53,5	50,3	46,5	42,1	31,6	17,7
P 3...-120/6	P 3...-120/6T	1,2	0,9	1,1	1,1	5,1	2,5	66,6	64,4	60,8	56,0	50,7	38,1	22,4
P 3...-150/7	P 3...-150/7T	1,5	1,1	1,4	1,4	6,6	3,1	75,6	73,3	69,4	64,8	58,9	44,4	26,1
P 3...-180/8	P 3...-180/8T	2	1,5	1,5	1,5	7,0	3,2	86,7	83,9	79,3	73,9	67,3	51,0	29,9
P 3...-200/9	P 3...-200/9T	2	1,5	1,7	1,6	7,6	3,3	97,0	93,8	88,5	82,5	74,7	56,4	32,9
P 3...-250/10	P 3...-250/10T	2	1,5	1,9	1,7	8,6	3,5	107,2	103,4	97,3	90,5	82,0	61,5	35,6
P 3...-280/11	P 3...-280/11T	2,5	1,85	2,1	1,9	9,8	3,9	117,2	112,8	106,6	98,8	89,8	66,8	37,3
P 3...-300/12	P 3...-300/12T	2,5	1,85	2,2	2,1	10,2	4,1	126,4	121,3	114,5	106,1	95,9	71,7	40,0

TYPE - 50 Hz		P2		P1		CURRENT		Q (m³/h - l/min)							
1-	3-			1-	3-	1- 230V	3- 400V	0	1,8	2,4	3,6	4,8	6	7,2	8,4
								0	30	40	60	80	100	120	140
		HP	kW	kW		A									
P 5...-120/4	P 5...-120/4T	1,2	0,9	1,09	1,09	4,9	2,4	45,5	42,2	40,7	37,2	32,9	27,4	19,8	10,4
P 5...-150/5	P 5...-150/5T	1,5	1,1	1,4	1,3	6,6	3,1	55,9	52,8	51,4	48,1	43,4	37,3	28,3	16,4
P 5...-180/6	P 5...-180/6T	2	1,5	1,6	1,6	7,4	3,3	67,0	63,3	61,6	57,6	51,9	44,2	33,6	20,4
P 5...-200/7	P 5...-200/7T	2	1,5	1,9	1,8	8,6	3,6	77,8	73,5	71,3	66,3	59,6	50,7	38,0	22,4
P 5...-250/8	P 5...-250/8T	2,5	1,85	2,2	2,1	9,9	4,1	89,2	83,9	81,6	76,2	68,4	58,3	43,2	24,6
P 5...-280/9	P 5...-280/9T	2,5	1,85	2,4	2,3	10,9	4,3	99,7	93,7	90,9	84,1	75,2	64,1	47,4	25,9
P 5...-300/10	P 5...-300/10T	3	2,2	2,7	2,6	12,5	4,9	112,2	105,4	102,4	95,3	85,6	72,6	54,8	31,0
P 5...-350/11	P 5...-350/11T	3,5	2,57	3,0	2,9	13,7	5,3	125,1	117,6	114,3	106,1	95,5	80,9	60,9	34,8
-	P 5...-380/12T	4	3	-	3,2	-	6,0	135,7	128,9	125,6	117,7	106,3	91,3	70,2	41,5

TYPE - 50 Hz		P2		P1		CURRENT		Q (m³/h - l/min)						
1-	3-			1-	3-	1- 230V	3- 400V	0	2,4	3,6	4,8	6	7,2	9,6
								0	40	60	80	100	120	160
		HP	kW	kW		A								
P 7...-180/4	P 7...-180/4T	2	1,5	1,8	1,7	8,3	3,5	46,7	46,0	45,2	43,1	40,3	36,9	25,5
P 7...-250/5	P 7...-250/5T	2,5	1,85	2,2	2,1	9,9	4,0	58,5	57,6	56,6	54,1	50,8	46,1	31,8
P 7...-300/6	P 7...-300/6T	3	2,2	2,6	2,5	12,1	4,8	70,6	69,9	68,7	65,8	61,8	56,6	39,3
-	P 7...-350/7T	3,5	2,57	-	2,9	-	5,3	82,8	82,0	80,6	77,2	72,3	66,0	46,4
-	P 7...-400/8T	4	3	-	3,3	-	6,1	94,8	94,3	92,5	88,6	83,2	76,4	52,6
-	P 7...-450/9T	4,5	3,37	-	3,7	-	6,7	107,4	106,9	105,2	101,1	95,3	87,7	61,0
-	P 7...-550/10T	5,5	4	-	4,1	-	7,9	119,8	119,6	118,4	113,9	107,7	99,4	70,4

TYPE - 50 Hz		P2		P1		CURRENT		Q (m³/h - l/min)							
1-	3-			1-	3-	1- 230V	3- 400V	0	3,6	4,8	6	7,2	9,6	12	13,2
								0	60	80	100	120	160	200	220
		HP	kW	kW		A									
P 9...-200/4	P 9...-200/4T	2	1,5	1,8	1,8	8,3	3,6	45,8	42,7	41,5	39,7	37,8	32,7	24,6	19,8
P 9...-250/5	P 9...-250/5T	2,5	1,85	2,3	2,2	10,4	4,2	57,1	53,1	51,6	49,5	47,2	40,6	30,2	24,4
P 9...-300/6	P 9...-300/6T	3	2,2	2,8	2,6	12,8	5,0	69,4	64,7	63,0	60,3	57,3	49,8	36,2	28,1
-	P 9...-400/7T	4	3	-	3,1	-	5,9	82,0	77,2	74,9	72,0	68,7	59,9	44,2	33,9
-	P 9...-450/8T	4,5	3,37	-	3,6	-	6,5	93,5	88,5	86,3	82,6	79,0	69,5	52,0	41,7
-	P 9...-500/9T	4,5	3,37	-	4	-	7	105,4	99,1	96,5	92,5	88,3	77,3	57,5	46,9
-	P 9...-550/10T	5,5	4	-	4,4	-	8,2	117,6	111,2	108,7	104,5	99,9	87,8	66,2	53,4

TYPE - 50 Hz		P2		P1	CURRENT		Q (m³/h - l/min)							
3-	3-				3- 400V	0	6	7,2	9,6	12	14,4	16,8	19,2	21,6
				0		100	120	160	200	240	280	320	360	400
		HP	kW	kW	A									
P 18...-250/3T	2,5	1,85	2,3	4,3	33,8	31,6	31,0	29,4	27,4	25,4	23,2	20,4	16,3	11,5
P 18...-400/4T	4	3	3,1	5,9	46,3	44,2	43,4	41,4	39,1	36,7	34,1	30,8	25,6	19,0
P 18...-450/5T	4,5	3,37	3,9	6,9	58,1	55,7	54,6	52,1	49,3	46,3	42,9	38,7	32,2	24,0
P 18...-550/6T	5,5	4	4,7	8,5	70,1	67,4	66,3	63,4	60,0	56,4	52,4	47,6	39,6	29,9
P 18...-750/8T	7,5	5,5	6,2	11,2	94,2	90,6	89,1	85,3	80,9	76,2	71,1	65,0	54,6	41,4
P 18...-900/9T	10	7,5	7	12,9	106,4	102,8	101,3	97,2	92,4	87,3	81,6	75,0	63,5	48,5

# PLUS SV/SL/SLX

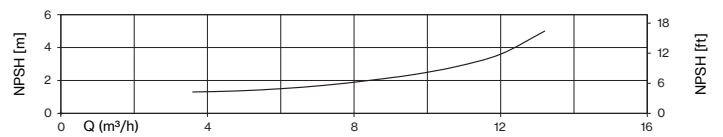
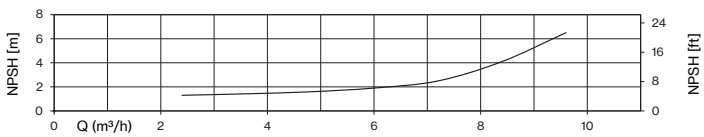
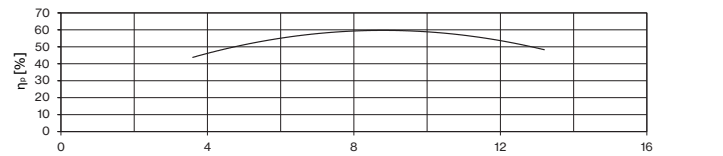
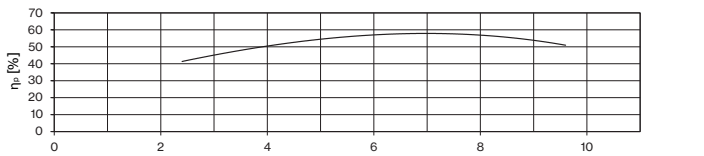
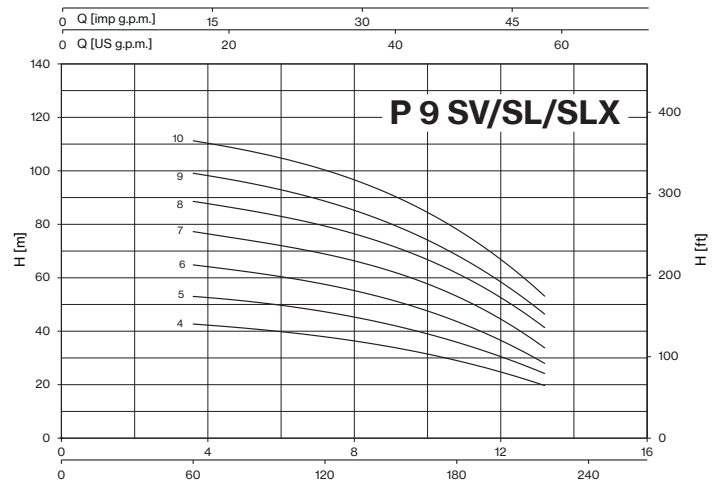
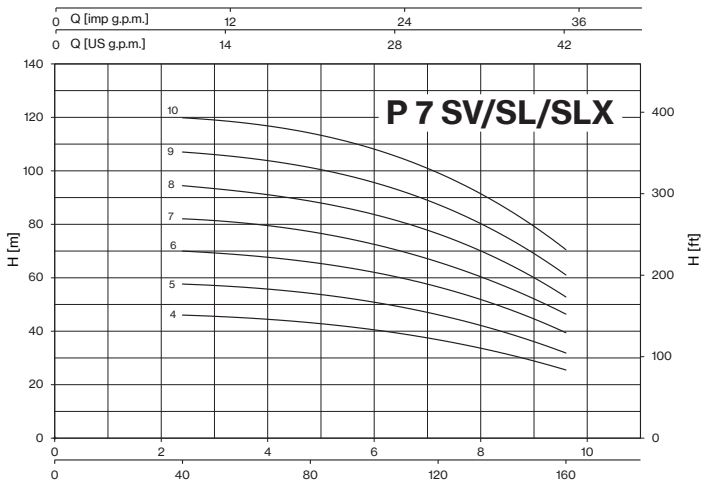
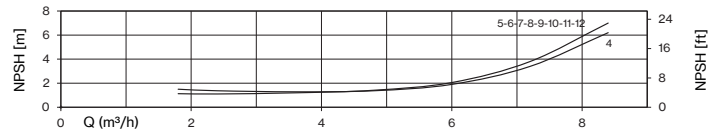
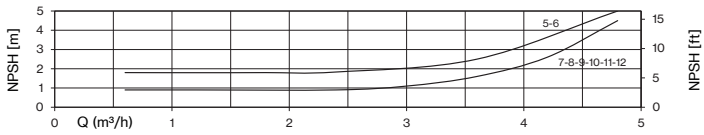
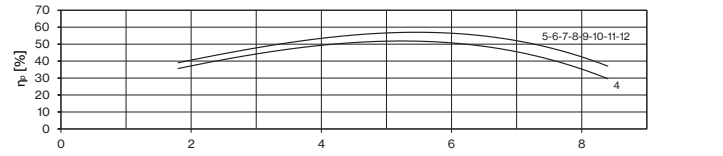
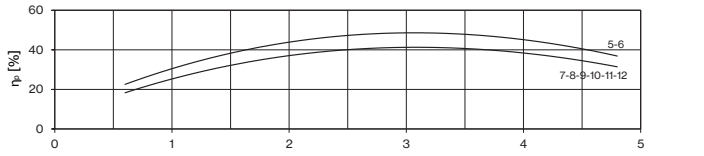
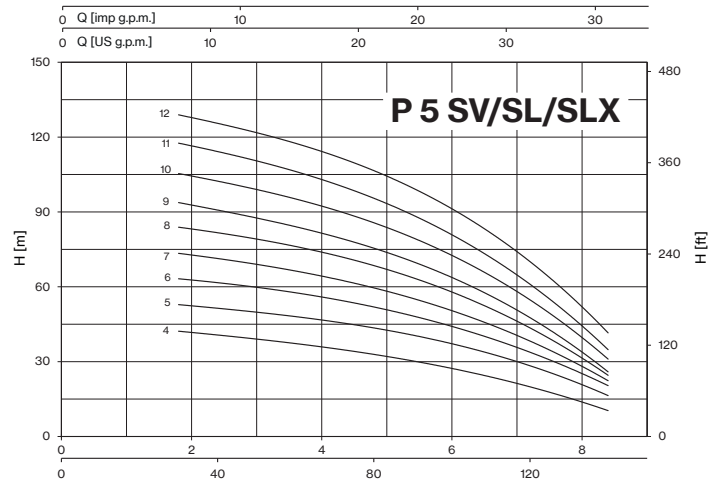
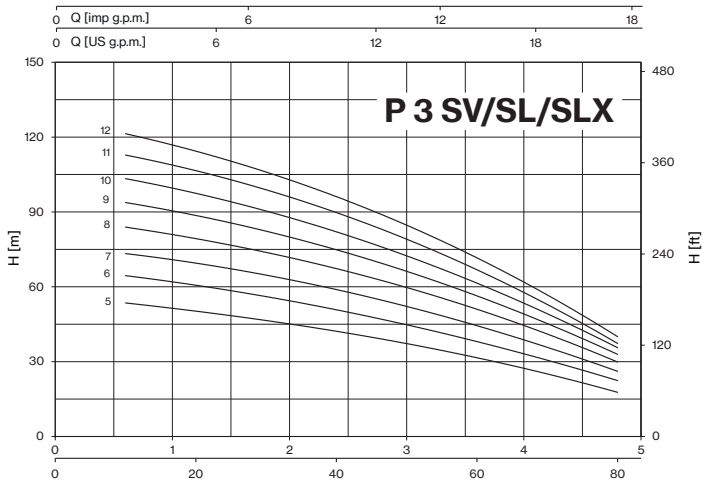

# PLUS SV/SL/SLX

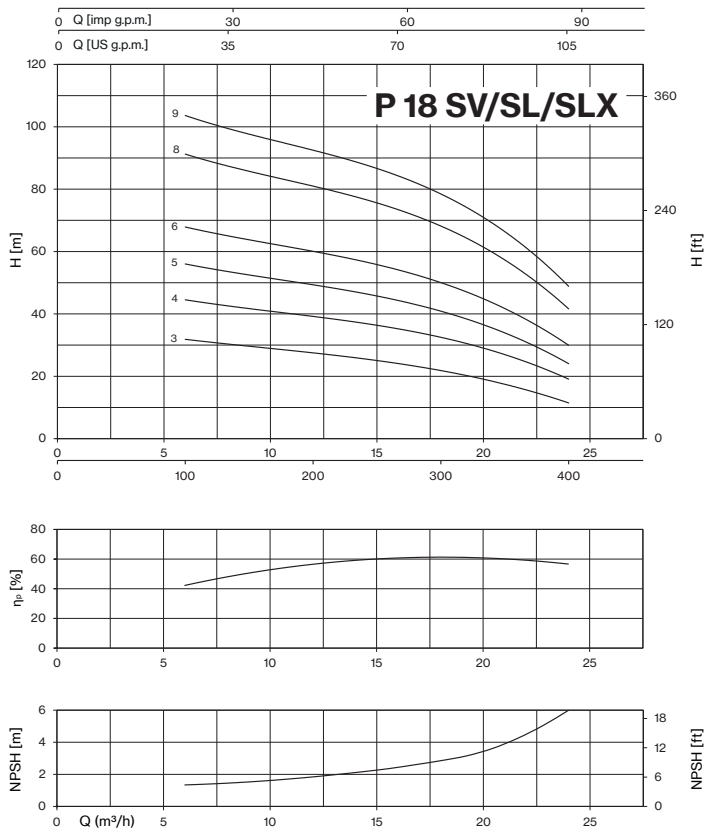

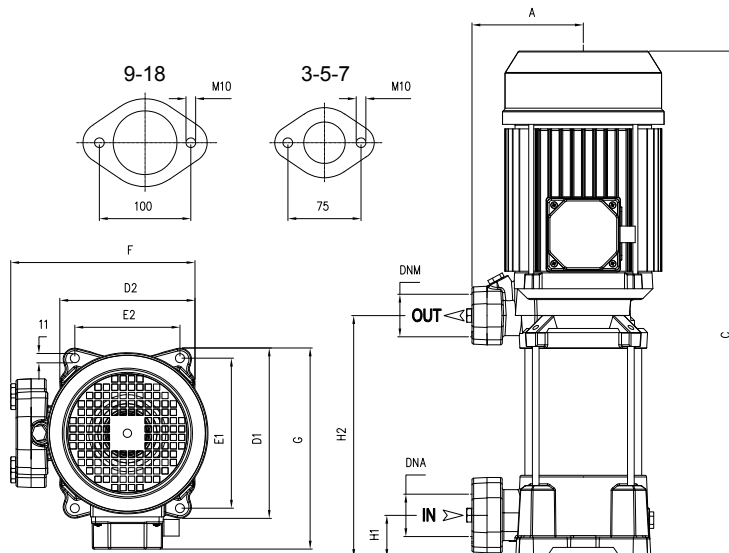

TYPE		DIMENSIONS (mm)												Kg	
-1	-3	A	C	D1	D2	E1	E2	F	G	H1	H2	DNA	DNM	-1	-3
P 3SV-100/5	P 3SV-100/5T	135	413	204	162	178,5	125	229	213	40	178	1" ¼ G	1" ¼ G	18,5	18,5
P 3SV-120/6	P 3SV-120/6T	135	437	204	162	178,5	125	229	213	40	202			19,5	19,5
P 3SV-150/7	P 3SV-150/7T	135	521	204	162	178,5	125	229	220	40	226			26,5	26,5
P 3SV-180/8	P 3SV-180/8T	135	545	204	162	178,5	125	229	220	40	250			26,5	26,5
P 3SV-200/9	P 3SV-200/9T	135	569	204	162	178,5	125	229	220	40	274			27,5	27,5
P 3SV-250/10	P 3SV-250/10T	135	593	204	162	178,5	125	229	220	40	298			28,5	28,5
P 3SV-280/11	P 3SV-280/11T	135	672 T 617	204	162	178,5	125	229	228 T 220	40	322	1" ¼ G	1" ¼ G	32	29
P 3SV-300/12	P 3SV-300/12T	135	696 T 641	204	162	178,5	125	229	228 T 220	40	346			32,5	28
P 5SV-120/4	P 5SV-120/4T	135	389	204	162	178,5	125	229	213	40	178			1" ¼ G	1" ¼ G
P 5SV-150/5	P 5SV-150/5T	135	473	204	162	178,5	125	229	220	40	202	25,5	25,5		
P 5SV-180/6	P 5SV-180/6T	135	497	204	162	178,5	125	229	220	40	226	26	26		
P 5SV-200/7	P 5SV-200/7T	135	521	204	162	178,5	125	229	220	40	250	25,5	26,5		
P 5SV-250/8	P 5SV-250/8T	135	545	204	162	178,5	125	229	220	40	274	27	26		
P 5SV-280/9	P 5SV-280/9T	135	624 T 569	204	162	178,5	125	229	228 T 220	40	298	31	26,5		
P 5SV-300/10	P 5SV-300/10T	135	648 T 593	204	162	178,5	125	229	228 T 220	40	322	35,5	28		
P 5SV-350/11	P 5SV-350/11T	135	672	204	162	178,5	125	229	228	40	346	36	33		
-	P 5SV-380/12T	135	696	204	162	178,5	125	229	228	40	370	-	35,5		
P 7SV-180/4	P 7SV-180/4T	135	422	204	162	178,5	125	229	220	40	178	1" ¼ G	1" ¼ G	23,5	25
P 7SV-250/5	P 7SV-250/5T	135	473	204	162	178,5	125	229	220	40	202			25	24
P 7SV-300/6	P 7SV-300/6T	135	552 T 497	204	162	178,5	125	229	228 T 220	40	226			32,5	26
-	P 7SV-350/7T	135	575	204	162	178,5	125	229	228	40	250			-	30
-	P 7SV-400/8T	135	600	204	162	178,5	125	229	228	40	274			-	33,5
-	P 7SV-450/9T	135	653	204	162	178,5	125	235	243	40	301			-	39
-	P 7SV-550/10T	135	676	204	162	178,5	125	235	243	40	325	-	44		
P 9SV-200/4	P 9SV-200/4T	135	473	204	162	178,5	125	229	220	40	202	1" ½ G	1" ¼ G	24	25
P 9SV-250/5	P 9SV-250/5T	135	503	204	162	178,5	125	229	220	40	232			25,5	24,5
P 9SV-300/6	P 9SV-300/6T	135	588 T 533	204	162	178,5	125	229	228 T 220	40	262			33	26,5
-	P 9SV-400/7T	135	617	204	162	178,5	125	229	228	40	292			-	33,5
-	P 9SV-450/8T	135	677	204	162	178,5	125	235	243	40	325			-	39
-	P 9SV-500/9T	135	707	204	162	178,5	125	235	243	40	355			-	39,5
-	P 9SV-550/10T	135	737	204	162	178,5	125	235	243	40	385	-	45		
-	P 18SV-250/3T	135	481	204	162	178,5	125	229	220	50	211	2" G	1" ½ G	-	25
-	P 18SV-400/4T	135	573	204	162	178,5	125	229	228	50	248			-	33,5
-	P 18SV-450/5T	135	640	204	162	178,5	125	235	243	50	289			-	39,5
-	P 18SV-550/6T	135	678	204	162	178,5	125	235	243	50	326			-	44,5
-	P 18SV-750/8T	135	815	204	162	178,5	125	255	253	50	401			-	55,5
-	P 18SV-900/9T	135	852	204	162	178,5	125	255	253	50	439			-	62

# PLUS SL/SLX

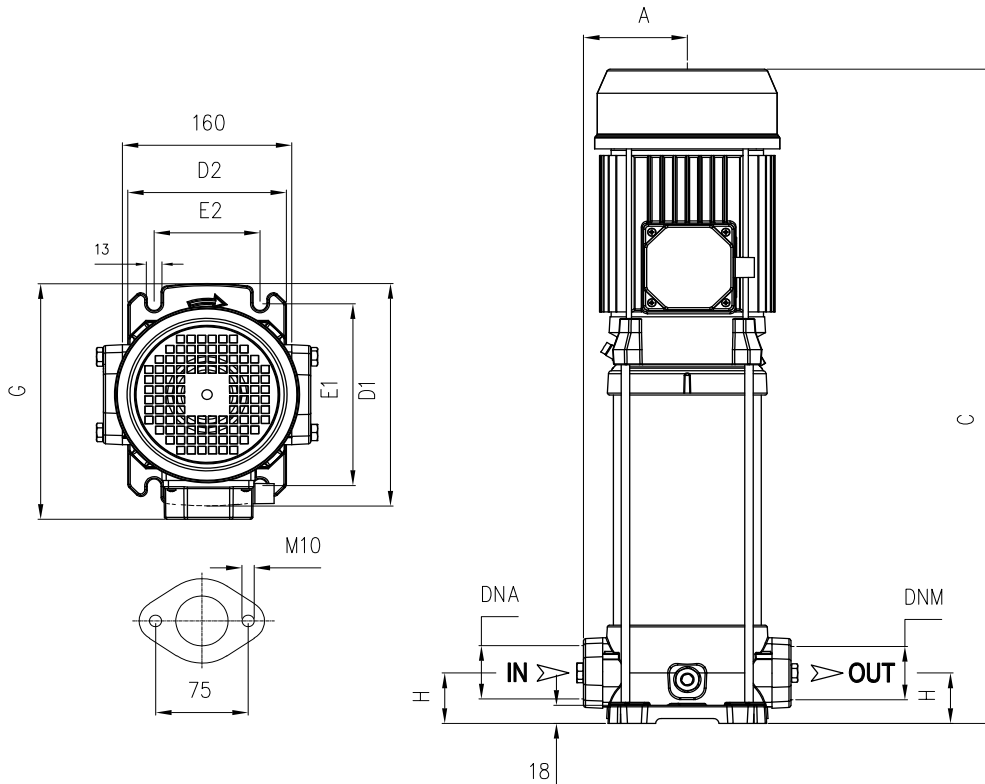

TYPE		DIMENSIONS (mm)										Kg					
												SL		SLX			
-1	-3	A	C	D1	D2	E1	E2	G	H	DNA	DNM	-1	-3	-1	-3		
P 3...-100/5	P 3...-100/5T	98	429	220	150	180	100	228	50	1" ¼ G	1" ¼ G	19	19	19	19		
P 3...-120/6	P 3...-120/6T	98	453	220	150	180	100	228	50			21,5	21,5	20	20		
P 3...-150/7	P 3...-150/7T	98	537	220	150	180	100	228	50			28,5	28,5	27,5	27,5		
P 3...-180/8	P 3...-180/8T	98	561	220	150	180	100	228	50			28,5	28,5	27,5	27,5		
P 3...-200/9	P 3...-200/9T	98	585	220	150	180	100	228	50			30,5	30,5	29	29,5		
P 3...-250/10	P 3...-250/10T	98	609	220	150	180	100	228	50			31,5	31,5	30,5	30,5		
P 3...-280/11	P 3...-280/11T	98	688 T 633	220	150	180	100	236 T 228	50			35,5	32,5	34	31		
P 3...-300/12T	P 3...-300/12T	98	712 T 657	220	150	180	100	236 T 228	50			36	31,5	34,5	30		
P 5...-120/4	P 5...-120/4T	98	405	220	150	180	100	221	50			1" ¼ G	1" ¼ G	20	20	19	19
P 5...-150/5	P 5...-150/5T	98	489	220	150	180	100	228	50					27,5	27,5	26,5	26,5
P 5...-180/6	P 5...-180/6T	98	513	220	150	180	100	228	50	28	28			26,5	27		
P 5...-200/7	P 5...-200/7T	98	537	220	150	180	100	228	50	27,5	28,5			26	27,5		
P 5...-250/8	P 5...-250/8T	98	561	220	150	180	100	228	50	29	28			28	27		
P 5...-280/9	P 5...-280/9T	98	640 T 585	220	150	180	100	236 T 228	50	34	29,5			33	28,5		
P 5...-300/10	P 5...-300/10T	98	664 T 609	220	150	180	100	236 T 228	50	37,5	31			36,5	30		
P 5...-350/11	P 5...-350/11T	98	687	220	150	180	100	236	50	38,5	35,5			37	34		
-	P 5...-380/12T	98	711	220	150	180	100	236	50	-	39			-	37,5		
P 7...-180/4	P 7...-180/4T	98	465	220	150	180	100	228	50	1" ¼ G	1" ¼ G			26	27	24,5	26
P 7...-250/5	P 7...-250/5T	98	489	220	150	180	100	228	50			27,5	26,5	26	25		
P 7...-300/6	P 7...-300/6T	98	568 T 513	220	150	180	100	236 T 228	50			35	28	34	27		
-	P 7...-350/7T	98	590	220	150	180	100	236	50			-	33	-	32		
-	P 7...-400/8T	98	614	220	150	180	100	236	50			-	36,5	-	35,5		
-	P 7...-450/9T	98	668	220	150	180	100	251	50			-	41	-	40		
-	P 7...-550/10T	98	692	220	150	180	100	251	50			-	46,5	-	45		

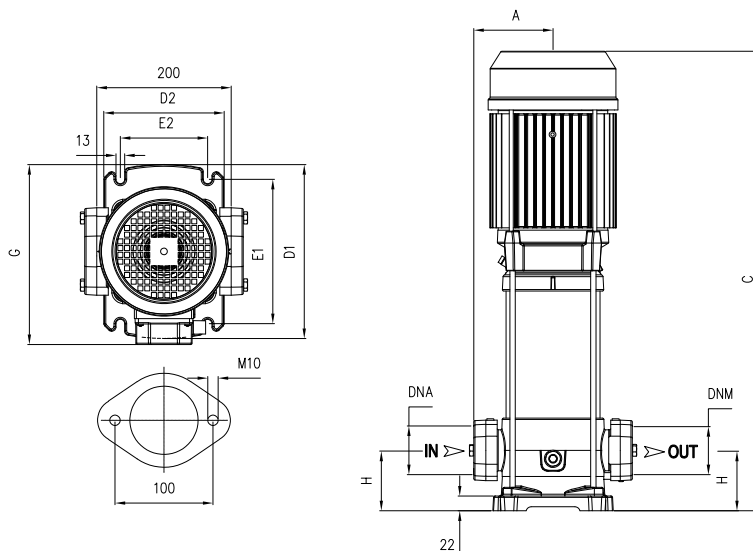



TYPE		DIMENSIONS (mm)										Kg					
												SL		SLX			
-1	-3	A	C	D1	D2	E1	E2	G	H	DNA	DNM	-1	-3	-1	-3		
P 9...-200/4	P 9...-200/4T	118	520	260	180	215	130	248	80	1" 1/2 G	1" 1/2 G	30	31	28,5	29,5		
P 9...-250/5	P 9...-250/5T	118	550	260	180	215	130	248	80			32	31	30,5	29,5		
P 9...-300/6	P 9...-300/6T	118	635 T 580	260	180	215	130	256 T 248	80			39,5	33	38	31,5		
-	P 9...-400/7T	118	663	260	180	215	130	256	80			-	40	-	38,5		
-	P 9...-450/8T	118	723	260	180	215	130	271	80			-	45	-	43,5		
-	P 9...-500/9T	118	763	260	180	215	130	271	80			-	45,5	-	44		
-	P 9...-550/10T	118	783	260	180	215	130	271	80			-	51	-	49		
-	P 18...-250/3T	118	482	260	180	215	130	251	90			2" G	2" G	-	30,5	-	29,5
-	P 18...-400/4T	118	603	260	180	215	130	257	90					-	39	-	37,5
-	P 18...-450/5T	118	680	260	180	215	130	271	90					-	44,5	-	43
-	P 18...-550/6T	118	718	260	180	215	130	271	90	-	49,5			-	48		
-	P 18...-750/8T	118	855	260	180	215	130	280	90	-	60			-	58,5		
-	P 18...-900/9T	118	893	260	180	215	130	280	90	-	66,5			-	65		

MODEL	LOTS			
	TRUCK		CONTAINER	
	PALLET (cm)	N° pumps	PALLET (cm)	N° pumps
P 3SV-100/5-200/9	80x120x150	42	80x120x175	49
P 3SV-250/10-300/12	80x120x155	30	80x120x180	35
P 3SV-300/12T	80x120x150	42	80x120x175	49
P 5SV-120/4-250/8	80x120x150	42	80x120x175	49
P 5SV-280/9T-300/10T	80x120x150	42	80x120x175	49
P 5SV-280/9-300/10	80x120x155	30	80x120x180	35
P 5SV-350/11-380/12T	80x120x155	30	80x120x180	35
P 7SV-180/4-350/7T	80x120x150	42	80x120x175	49
P 7SV-400/8T	80x120x155	30	80x120x180	35
P 7SV-450/9T-550/10T	85x110x125	20	85x110x150	24
P 9SV-200/4	80x120x150	42	80x120x175	49
P 9SV-250/5-300/6T	80x120x150	42	80x120x175	49
P 9SV-300/6-400/7T	80x120x155	30	80x120x180	35
P 9SV-450/8T-550/10T	85x110x125	20	85x110x150	24
P 18SV-250/3T-400/4T	80x120x150	42	80x120x175	49
P 18SV-450/5T-550/6T	85x110x125	20	85x110x150	24
P 18SV-750/8T-900/9T	100x120x150	12	100x120x150	12

MODEL	LOTS			
	TRUCK		CONTAINER	
	PALLET (cm)	N° pumps	PALLET (cm)	N° pumps
P 3SL/SLX-100/5-180/8	85x110x150	36	85x110x170	42
P 3SL/SLX-200/9-300/12	80x120x150	30	80x120x170	35
P 5SL/SLX-120/4-250/8	85x110x150	36	85x110x170	42
P 5SL/SLX-280/9-380/12T	80x120x150	30	80x120x170	35
P 7SL/SLX-180/4-300/6T	85x110x150	36	85x110x170	42
P 7SL/SLX-300/6-400/8T	80x120x150	30	80x120x170	35
P 7SL/SLX-450/9T-550/10T	80x120x150	30	80x120x170	35
P 9SL/SLX-200/4-400/7T	80x120x155	25	80x120x185	30
P 9SL/SLX-450/8T-550/10T	85x110x150	20	85x110x150	20
P 18SL/SLX-250/3T-400/4T	80x120x155	25	80x120x185	30
P 18SL/SLX-450/5T-550/6T	85x110x150	20	85x110x150	20
P 18SL/SLX-750/8T-900/6T	85x110x150	20	85x110x150	20

# PLUS V-SV-L-SL-LG-SLG Serie-Mechanical seal and bearings

MECHANICAL SEAL	PUMP MODEL	SHAFT		STANDARD MATERIAL	OPTIONAL
					2
	P3-100/5, P3-120/6, P5-120/4, P5-150/5, P5-180/6, P7-180/4, P7-250/5, P7-300/6, P9-200/4, P9-250/5, P18-250/3, P18-400/4	14mm / S	<b>Rotating face</b> <b>Stationary face</b> <b>Elastomer</b>	Graphite Ceramic EPDM	SiC SiC EPDM
	P3-150/7, P3-180/8, P3-200/9, P3-250/10, P3-280/11, P3-300/12, P5-200/7, P5-250/8, P5-280/9, P5-300/10, P5-350/11, P5-380/12, P7-350/7, P7-400/8, P7-450/9, P7-550/10, P9-300/6, P9-400/7, P9-450/8, P9-500/9, P9-550/10	14mm	<b>Rotating face</b> <b>Stationary face</b> <b>Elastomer</b>	Graphite SiC EPDM	SiC SiC EPDM
	P18-450/5, P18-550/6, P18-750/8, P18-900/9, P18-920/10, P18-1000/11	14mm / L	<b>Rotating face</b> <b>Stationary face</b> <b>Elastomer</b>	Graphite SiC EPDM	SiC SiC EPDM
	P3-350/14, P3-380/16, P3-400/18, P3-450/20, P5-400/14, P5-450/16, P5-550/18, P5-600/20, P7-750/12, P7-800/14, P7-900/16, P7-950/18, P7-1000/20, P9-750/12, P9-800/14, P9-900/16, P9-950/18, P9-1000/20	14mm / Balanced seal	<b>Rotating face</b> <b>Stationary face</b> <b>Elastomer</b>	Tungsten carbide Graphite EPDM	- - -

BEARINGS	PUMP MODEL	TYPE	
	P3-100/5, P3-120/6, P5-120/4	6202-ZZ	6302-ZZ C3
	P3-150/7, P3-180/8, P3-200/9, P3-250/10, 3- P3-280/11, 3- P3-300/12, P5-150/5, P5-180/6, P5-200/7, P5-250/8, 3- P5-280/9, 3- P5-300/10, P7-180/4, P7-250/5, 3- P7-300/6, P9-200/4, P9-250/5, 3- P9-300/6, P18-250/3	6203-ZZ	6304-ZZ C3
	1- P3-280/11, 1- P3-300/12, 1- P5-280/9, 1- P5-300/10, P5-350/11, P5-380/12, 1- P7-300/6, P7-350/7, P7-400/8, 1- P9-300/6, P9-400/7, P18-400/4, P3-350/14, P3-380/16, P3-400/18, P5-400/14	6203-ZZ	6305-ZZ C3
	P7-450/9, P7-550/10, P9-450/8, P9-500/9, P9-550/10, P18-450/5, P18-550/6	6204-ZZ	6306-ZZ-C3
	P3-450/20, P5-450/16, P5-550/18, P5-600/20	6204-ZZ	3206-ZZ C3
	P7-750/12, P7-800/14, P7-900/16, P9-750/12, P9-800/14, P9-900/16, P18-750/8, P18-900/9, P18-920/10	6206-ZZ C3	3306-ZZ C3
	P7-950/18, P7-1000/20, P9-950/18, P9-1000/20, P18-1000/11	6206-ZZ C3	3308-ZZ C3



# PLUS V/L/H + VSD

Vertical booster pump with variable speed drive

## PLUS V



EPIC / EPIC-A

IPFC

## PLUS L



EPIC / EPIC-A

IPFC

## PLUS H



EPIC / EPIC-A

IPFC

### DESCRIPTION

Vertical pump of PLUS series provided with variable speed drive EPIC, EPIC-A or IPFC. This booster pump assures a desired pressure regardless of changes on flow demand making it suitable for low or missing pressure in residential systems and industrial applications. It is required the installation of a membrane tank downstream the system.

### FEATURES

- EPIC, EPIC-A or IPFC variable speed drive
- Three-phase vertical pump of PLUS series
- Pressure sensor wired to the vsd
- Cable with plug for EPIC vsd only

### FUNCTIONING

If the pressure in the network drops the pump will start and gradually speeds up to provide with the set pressure. When the water demand decreases, the pressure will rise causing the pump speed to slow down and eventually to stop the pump if demand ceases. The pump will remain on standby waiting to start at the next water demand.

### SELECTION

The next table shows the vertical PLUS pump models available for the assembly with EPIC, EPIC-A or IPFC. For pumps longer than 1.4m, IPFC is not assembled onto the motor fan cover but is supplied with a wall-mounting kit. Consult the catalog at the PLUS series for pump specifics and characteristic curves.

**P3SL /A 100/5 T -304 3x400-50**

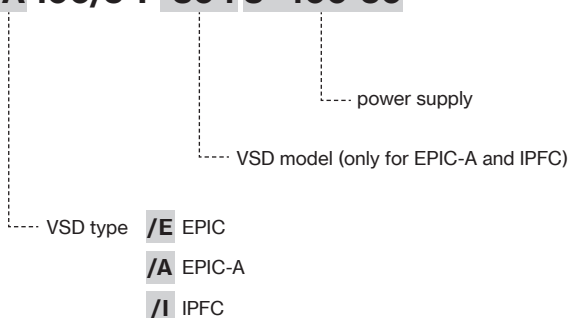

TYPE		3- PUMP						VSD TYPE			
		VERSION						Power supply			
		V	SV	L	SL/SLX	LG	SLG/SLGX	1-230V		3-400V	
P 3	100/5T	■	■	■	■	-	-	EPIC	IPFC 109	EPIC-A 304	IPFC 306
	120/6T	■	■	■	■	-	-				
	150/7T	■	■	■	■	-	-				
	180/8T	■	■	■	■	-	-				
	200/9T	■	■	■	■	-	-				
	250/10T	■	■	■	■	-	-				
	280/11T	■	■	■	■	-	-				
	300/12T	■	■	■	■	-	-				
	350/14T	-	-	-	-	-	■				
	380/16T	-	-	-	-	-	■				
	400/18T	-	-	-	-	-	■				
450/20T	-	-	-	-	-	■					
P 5	120/4T	■	■	■	■	-	-	EPIC	IPFC 109	EPIC-A 304	IPFC 306
	150/5T	■	■	■	■	-	-				
	180/6T	■	■	■	■	-	-				
	200/7T	■	■	■	■	-	-				
	250/8T	■	■	■	■	-	-				
	280/9T	■	■	■	■	-	-				
	300/10T	■	■	■	■	-	-				
	350/11T	■	■	■	■	-	-				
	380/12T	■	■	■	■	-	-				
	400/14T	-	-	-	-	-	■				
	450/16T	-	-	-	-	-	■				
550/18T	-	-	-	-	-	■					
600/20T	-	-	-	-	-	■					
P 7	180/4T	■	■	■	■	-	-	EPIC	IPFC 109	EPIC-A 304	IPFC 306
	250/5T	■	■	■	■	-	-				
	300/6T	■	■	■	■	-	-				
	350/7T	■	■	■	■	-	-				
	400/8T	■	■	■	■	-	-				
	450/9T	■	■	■	■	-	-				
	550/10T	■	■	■	■	-	-				
	750/12T	-	-	-	-	-	■				
	800/14T	-	-	-	-	-	■				
	900/16T	-	-	-	-	-	■				
	950/18T	-	-	-	-	-	■				
1000/20T	-	-	-	-	-	■					
P 9	200/4T	■	■	■	■	-	-	EPIC	IPFC 109	EPIC-A 304	IPFC 306
	250/5T	■	■	■	■	-	-				
	300/6T	■	■	■	■	-	-				
	400/7T	■	■	■	■	-	-				
	450/8T	■	■	■	■	-	-				
	500/9T	■	■	■	■	-	-				
	550/10T	■	-	■	-	-	-				
	750/12T	-	-	-	-	-	■				
	800/14T	-	-	-	-	-	■				
	900/16T	-	-	-	-	-	■				
	950/18T	-	-	-	-	-	■				
1000/20T	-	-	-	-	-	■					

# PLUS+VSD

		3- PUMP							VSD TYPE		
TYPE		VERSION							Power supply		
		V	SV	L	SL/SLX	LG	HS	HX	1-230V	3~400V	
P 18	100/1T	-	-	-	-	-	-	■	IPFC 109	EPIC-A 304	IPFC 306
	200/2T	-	-	-	-	-	-	■			
	300/3T	-	-	-	-	-	-	■			
	250/3T	■	■	■	■	-	-	-	IPFC 114	EPIC-A 306	
	400/4T	-	-	-	-	-	-	■			
	450/5T	■	■	■	■	-	-	-	-	-	
	550/5T	-	-	-	-	-	-	■			
	550/6T	■	■	■	■	-	-	-			
	750/6T	-	-	-	-	-	-	■			IPFC 311
	750/7T	-	-	-	-	-	-	■			
	750/8T	■	■	■	■	-	-	-			IPFC 314
	1000/8T	-	-	-	-	-	-	■			
	1000/9T	-	-	-	-	-	-	■			IPFC 318
	900/9T	■	■	■	■	-	-	-			
	920/10T	-	-	-	-	■	-	-			
	1000/11T	-	-	-	-	■	-	-			
	1500/10T	-	-	-	-	-	-	■			
	1500/11T	-	-	-	-	-	-	■			
	1500/12T	-	-	-	-	-	-	■			
	1500/13T	-	-	-	-	-	-	■			
1500/14T	-	-	-	-	-	-	■				
2000/15T	-	-	-	-	-	-	■				
2000/16T	-	-	-	-	-	-	■				
2000/17T	-	-	-	-	-	-	■	IPFC 325			
										IPFC 330	
P 22	200/1T	-	-	-	-	-	-	■	IPFC 109	-	IPFC 306
	300/2T	-	-	-	-	-	-	■			
	400/3T	-	-	-	-	-	-	■	IPFC 114		IPFC 309
	550/4T	-	-	-	-	-	-	■			
	750/5T	-	-	-	-	-	-	■			
	1000/6T	-	-	-	-	-	-	■	IPFC 311		
	1000/7T	-	-	-	-	-	-	■			
	1500/8T	-	-	-	-	-	-	■	IPFC 314		
	1500/9T	-	-	-	-	-	-	■			
	1500/10T	-	-	-	-	-	-	■	IPFC 318		
	2000/11T	-	-	-	-	-	-	■			
	2000/12T	-	-	-	-	-	-	■			
	2000/13T	-	-	-	-	-	-	■	IPFC 325		
	2000/14T	-	-	-	-	-	-	■			
										IPFC 330	

		3- PUMP							VSD TYPE	
TYPE		VERSION							Power supply	
		V	SV	L	SL/SLX	LG	HS	HX	1-230V	3-400V
P 35	300/1T	-	-	-	-	-	■	■	IPFC 114	IPFC 306
	550/2-2RT	-	-	-	-	-	■	■	-	IPFC 309
	550/2-1RT	-	-	-	-	-	■	■		IPFC 311
	750/2T	-	-	-	-	-	■	■		IPFC 314
	750/3-2RT	-	-	-	-	-	■	■		IPFC 318
	1000/3-1RT	-	-	-	-	-	■	■		IPFC 325
	1000/3T	-	-	-	-	-	■	■		
	1000/4-2RT	-	-	-	-	-	■	■		
	1500/4-1RT	-	-	-	-	-	■	■		
	1500/4T	-	-	-	-	-	■	■		
	1500/5-2RT	-	-	-	-	-	■	■		IPFC 330
	1500/5-1RT	-	-	-	-	-	■	■		
	2000/5T	-	-	-	-	-	■	■		
	2000/6-2RT	-	-	-	-	-	■	■		
	2000/6-1RT	-	-	-	-	-	■	■		-
	2000/6T	-	-	-	-	-	■	■		
2000/7-2RT	-	-	-	-	-	■	■			
2000/7-1RT	-	-	-	-	-	■	■			
P 50	400/1-1RT	-	-	-	-	-	■	■	IPFC 114	IPFC 306
	550/1T	-	-	-	-	-	■	■	-	IPFC 309
	750/2-2RT	-	-	-	-	-	■	■		IPFC 311
	1000/2T	-	-	-	-	-	■	■		IPFC 318
	1500/3-2RT	-	-	-	-	-	■	■		IPFC 325
	1500/3T	-	-	-	-	-	■	■		IPFC 330
	2000/4-2RT	-	-	-	-	-	■	■		-
	2000/4T	-	-	-	-	-	■	■		
	2500/5-2RT	-	-	-	-	-	■	■		
	2500/5T	-	-	-	-	-	■	■		
	3000/6-2RT	-	-	-	-	-	■	■		
	3000/6T	-	-	-	-	-	■	■		
	4000/7-2RT	-	-	-	-	-	■	■		
P 75	550/1-1RT	-	-	-	-	-	■	■	-	IPFC 309
	750/1T	-	-	-	-	-	■	■		IPFC 311
	1000/2-2RT	-	-	-	-	-	■	■		IPFC 318
	1500/2-1RT	-	-	-	-	-	■	■		IPFC 325
	1500/2T	-	-	-	-	-	■	■		IPFC 330
	2000/3-2RT	-	-	-	-	-	■	■		-
	2000/3-1RT	-	-	-	-	-	■	■		
	2500/3T	-	-	-	-	-	■	■		
	2500/4-2RT	-	-	-	-	-	■	■		
	3000/4-1RT	-	-	-	-	-	■	■		
	3000/4T	-	-	-	-	-	■	■		
4000/5-2RT	-	-	-	-	-	■	■			
P 90	750/1-1RT	-	-	-	-	-	■	■	-	IPFC 311
	1000/1T	-	-	-	-	-	■	■		IPFC 318
	1500/2-2RT	-	-	-	-	-	■	■		IPFC 325
	2000/2T	-	-	-	-	-	■	■		IPFC 330